

**2024**



**SUZUKI MARINE OUTBOARDS**  
**PARTS AND**  
**ACCESSORIES**  
**CATALOG**



Dear Customer,

The Suzuki Genuine Accessories Catalog provides information on the highest quality accessories, specific to your outboard engine and application. We strive to bring you only the highest quality parts to ensure your outboard will run flawlessly for years to come. We recommend only using Suzuki Genuine Accessories on your Suzuki outboard. We never compromise over quality and you shouldn't compromise your boating experience with anything but Suzuki Genuine Accessories. Suzuki is on the forefront of innovation and have the accessories to prove it. If you are thinking of bringing the foremost of technology to your boat, think Suzuki. Pair your Suzuki outboard with our dependable instruments and gauges, custom-engineered propellers, and durably designed rigging items for optimum performance and reliability. Take your time reading through our catalog, and don't hesitate to visit our website or an Authorized Suzuki Marine Dealer.

Thank you,

**Suzuki Parts & Accessories**

[www.suzukimarine.com](http://www.suzukimarine.com)



## TABLE OF CONTENTS

	Suzuki Precision Control 2.0	2
	Digital Instrumentation	10
	Mechanical Controls	24
	Analog Instruments	26
	Cables & Rigging	30
	Steering	32
	Fuel System	34
	Propellers	36
	DF300B & DF350 Propellers and Tools	38
	Repair Kits & Anodes	40
	Ecstar Oils & Chemicals	42
	Maintenance & Care	44
	Engine Covers	46
	Marine Style	48
	Gifts & Collectibles	54
	Application Chart	56
	Maintenance Kit	60

# SUZUKI PRECISION CONTROL 2.0

## Suzuki Precision Control 2.0 (S.P.C. 2.0) Electronic Throttle and Shift Systems

For DF115BG/140BG/150AP/175AP/200AP/250AP/250ATSS/300AP/300B/350A



**Single Engine S.P.C. 2.0 Binnacle**

67200-98L00 Single Engine S.P.C. 2.0 Binnacle Only



**Multi-Engine S.P.C. 2.0 Binnacle**

67200-98L10 Multi-Engine S.P.C. 2.0 Binnacle Only



**Flush Mount S.P.C. 2.0 Control**

67200-98L20 Flush Mount S.P.C. 2.0 Control Only



### Suzuki Precision Maneuvering

- Touch the future with Suzuki's Precision Maneuvering System and enjoy confident intuitive joystick control.
- Designed exclusively for Suzuki outboards with Suzuki Precision Controls, including the new DF115 and DF140 BG models as well as DF150AP, DF175AP, DF200AP, DF250AP, DF300AP, DF300B, and DF350A.
- Experience parallel parking without a thruster.
- Confidently pilot your boat around crowded docks, at waterfront restaurants and at the launch ramp.
- Now available for twin, triple, and quad installations.
- See your Local Authorized Suzuki SeaStar Installation Center for more details.



# SUZUKI PRECISION CONTROL 2.0 COMPONENTS

<b>1 Binnacle Mount R/C Box</b> 	<b>Flush Mount R/C Box</b> 	<b>2 Control Panels</b> 	
<b>3 Buzzer</b> 	<b>4 Boat Control Module (BCM)</b> 	<b>5 Terminal Resistor</b> 	<b>6 Battery Lead Wire</b> 
<b>7 BCM #1 Wiring Harness</b> 	<b>8 Emergency Switch Extension Harness</b> 	<b>9 Signal Unit Coverter</b> 	
<b>10 Dual Station Main Harness</b> 	<b>11 BCM #2 Wiring Harness</b> 	<b>12 Engine Wire Harness</b> 	
<b>13A Main Switch Panels</b> 	<b>13B 2nd Station / Push Button</b> 	<b>14 Emergency Switch Panel</b> 	<b>15 Main Wiring Harness</b> 
		<b>17 Troll Mode Switch</b> 	

# SINGLE ENGINE S.P.C. 2.0 CONTROL KITS

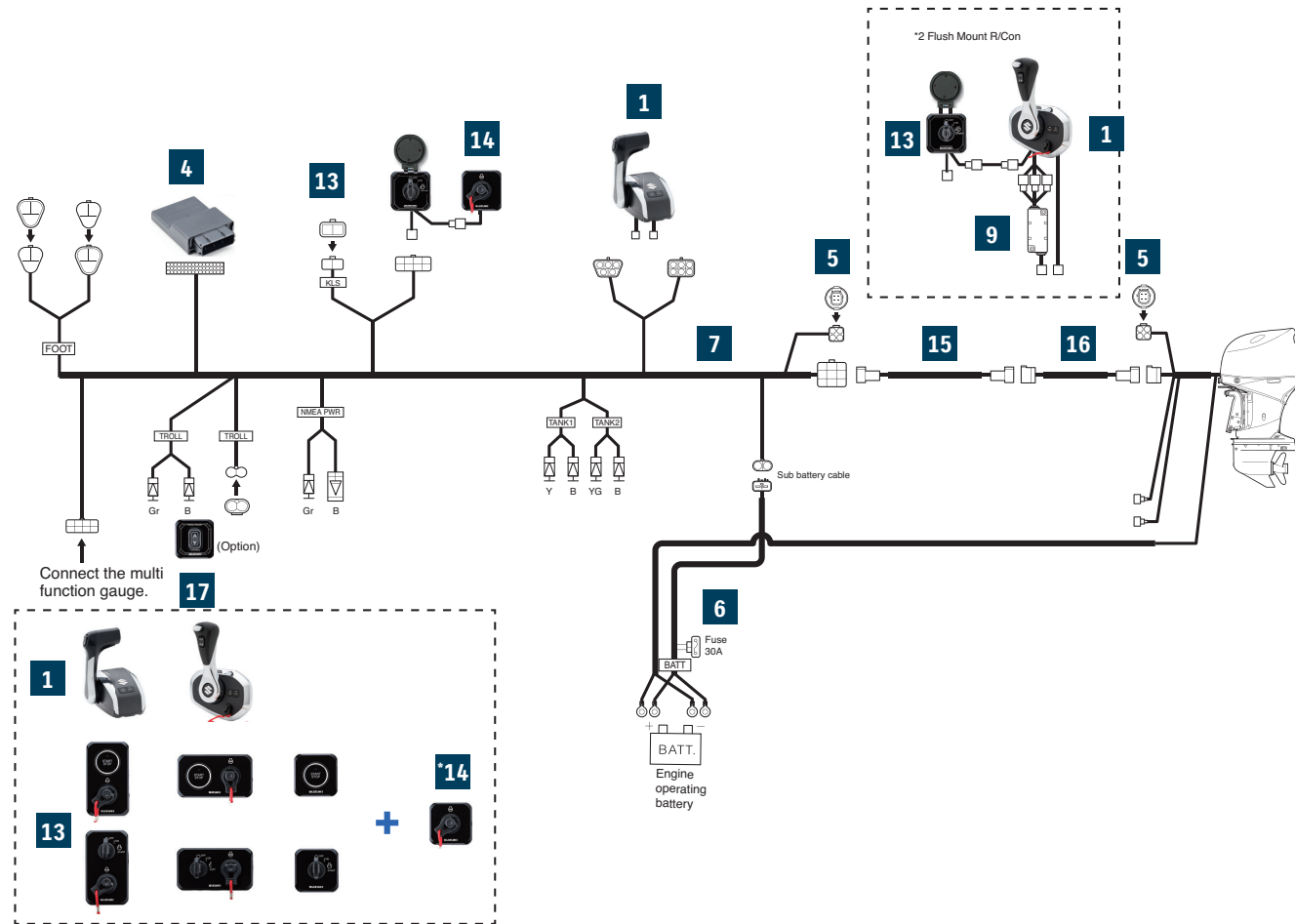

# DUAL ENGINE S.P.C. 2.0 CONTROL KITS

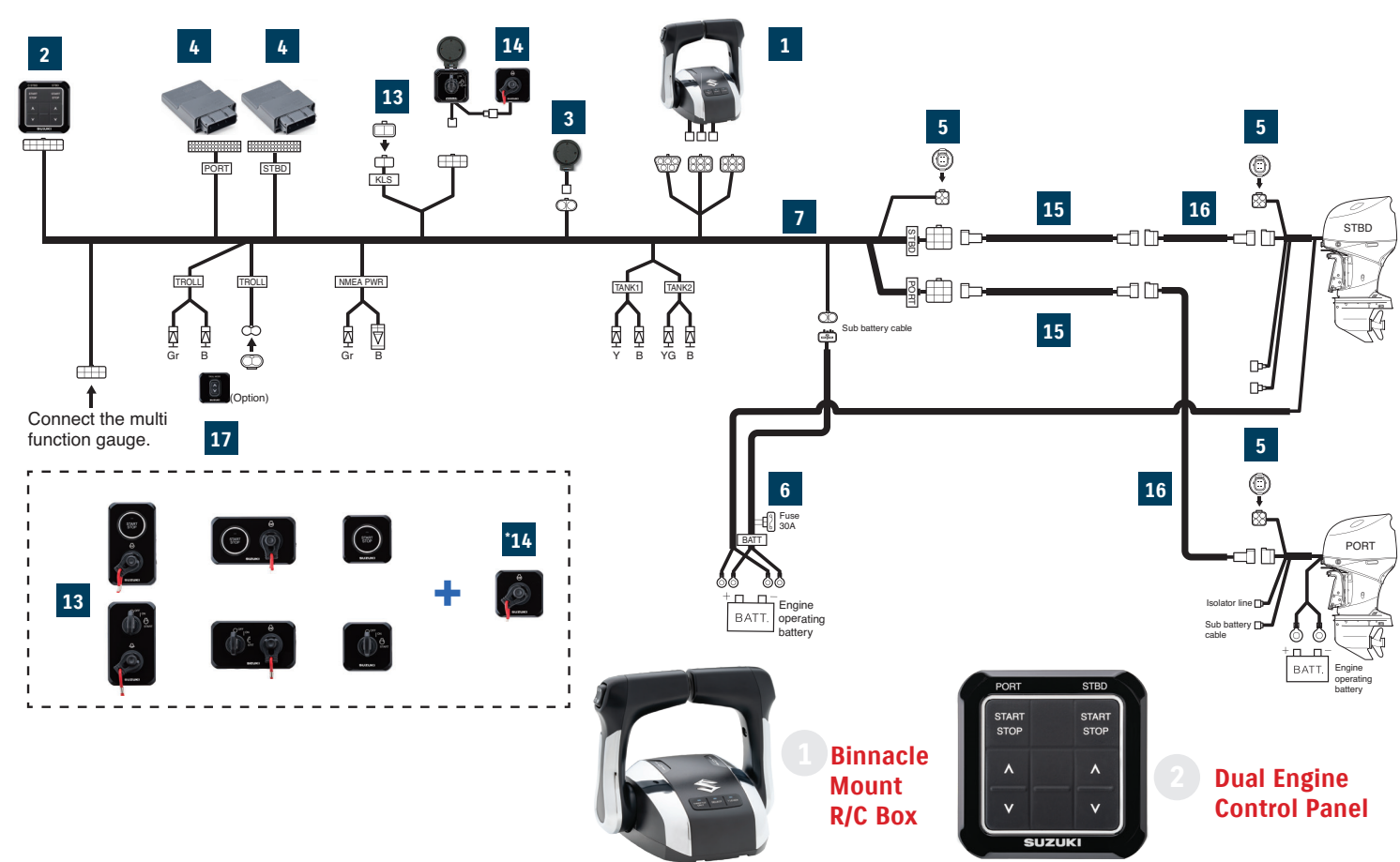

## SINGLE ENGINE SPC 2.0 CONTROL KITS

	67000-98L02 1st Binnacle Kit	67000-98LA0 2nd Binnacle Kit	67000-98L12 Flush Mount Kit	67000-98LB1 2nd Flush Kit
1	67200-98L00 Binnacle Mount R/C Box	1	-	-
	67200-98L20 Flush Mount R/C Box	-	1	1
3	38500-93J90 Warning Buzzer	-	1	1
	09407-08401 Warning Buzzer Clamp	1	-	1
	36770-98L02 Boat Control Module	1	1	1
4	36775-98L00 BCM Holder (L)	1	1	1
	36776-98L00 BCM Holder (R)	1	1	1
	33925-98L00 BCM Cushion	1	1	1
5	33926-98L00 Terminal Resistor	2	2	-
6	36625-98J10 Battery - Lead	1	1	-
7	36623-98L00 BCM #1 Wiring Harness	1	1	-
8	36627-98L10 Harness Assy, Emergency Switch Ext.	-	1	1
9	37140-98L00 Signal Converter	-	1	1
10	36622-98L00 Dual - Station Wiring Harness	1	-	1
11	36624-98L00 BCM #2 Wiring Harness	-	1	1
-	09403-13402 Harness Clamp	10	10	10
13A*	37100-98L00 Modular Ignition Switch	Choose 1*	Choose 1*	
	37100-98L10 Vertical Ignition Switch			
	37100-98L20 Horizontal Ignition Switch			
13B*	37290-98L00 Modular Push Button Ignition	Choose 1*		37290-98L00 (Purchase separately)
	37290-98L10 Vertical Push Button Ignition			
	37290-98L20 Horizontal Push Button Ignition			
14***	37803-98L00 Modular Emergency Switch	1***		
15	36620-98L00 21' Main Wiring Harness	Select required length, 1 required		
	36620-98L10 31' Main Wiring Harness	Select if necessary		
16	36620-98L20 6.5' Main Harness Extension	Select if necessary		
17	37860-98L00 Troll Mode Switch	Optional		
18	36627-98L00 R/C Extension Harness		1****	1****
19	990C0-98L70 Digital Foot Throttle	Must be used in conjunction with existing SPC 2.0 control, single engine only		

## DUAL ENGINE S.P.C. 2.0 CONTROL KITS

	67000-98L22 1st Station Kit	67000-98LC2 2nd Station Kit	
1	67200-98L10 Binnacle Remote Control Box	1	
2	37120-98L00 Control Panel	1	
3	38500-93J90 Warning Buzzer	1	
	39407-08401 Warning Buzzer Clamp	2	
4	36770-98L02 Boat Control Module (BCM)	2	
	36775-98L00 BCM Holder (L)	2	
	36776-98L00 BCM Holder (R)	2	
	33925-98L00 BCM Cushion	2	
5	33926-98L00 Terminal Resistor	3	
6	36625-98J10 Battery - Lead	1	
7	36623-98L30 BCM #1 Wiring Harness	1	
10	36622-98L00 Dual - Station Wiring Harness	-	
11	36624-98L10 BCM #2 Wiring Harness	-	
-	09403-13402 Harness Clamp	15	
-	36612-98J20 Counter Rotation Adapter	1	
13A*	37100-98L00 Modular Ignition Switch	Choose 1*	
	37100-98L10 Vertical Ignition Switch		
	37100-98L20 Horizontal Ignition Switch		
13B*	37290-98L00 Modular Push Button Ignition	Choose 1**	
	37290-98L10 Vertical Push Button Ignition		
	37290-98L20 Horizontal Push Button Ignition		
14***	37803-98L00 Modular Emergency Switch	1***	
15	36620-98L00 21' Main Wiring Harness	Select required length, 2 required	Select required length, 2 required
	36620-98L10 31' Main Wiring Harness	Select if necessary	Select if necessary
16	36620-98L20 6.5' Main Harness Extension	Select if necessary	Select if necessary
17	37860-98L00 Troll Mode Switch	Optional	
18	36627-98L00 R/C Extension Harness	Select if necessary	

\*Switch panels are sold separately, select type  
 \*\*Push button ignition switches for 2nd station only  
 \*\*\* Required when using 37100-98L00 or 37290-98L00 with binnacle kit.  
 Flush mount kit has integrated emergency stop on control  
 \*\*\*\*Required when using Flush Mount Control kit

Single Station wiring diagram above is for reference only, please refer to your engine set up manual for complete setup instructions

\*Switch panels are sold separately, select type  
 \*\*Push button ignition switches for 2nd station only  
 \*\*\* Required when using 37100-98L00 or 37290-98L00

Single Station wiring diagram above is for reference only, please refer to your engine set up manual for complete setup instructions

# TRIPLE ENGINE S.P.C. 2.0 CONTROL KITS

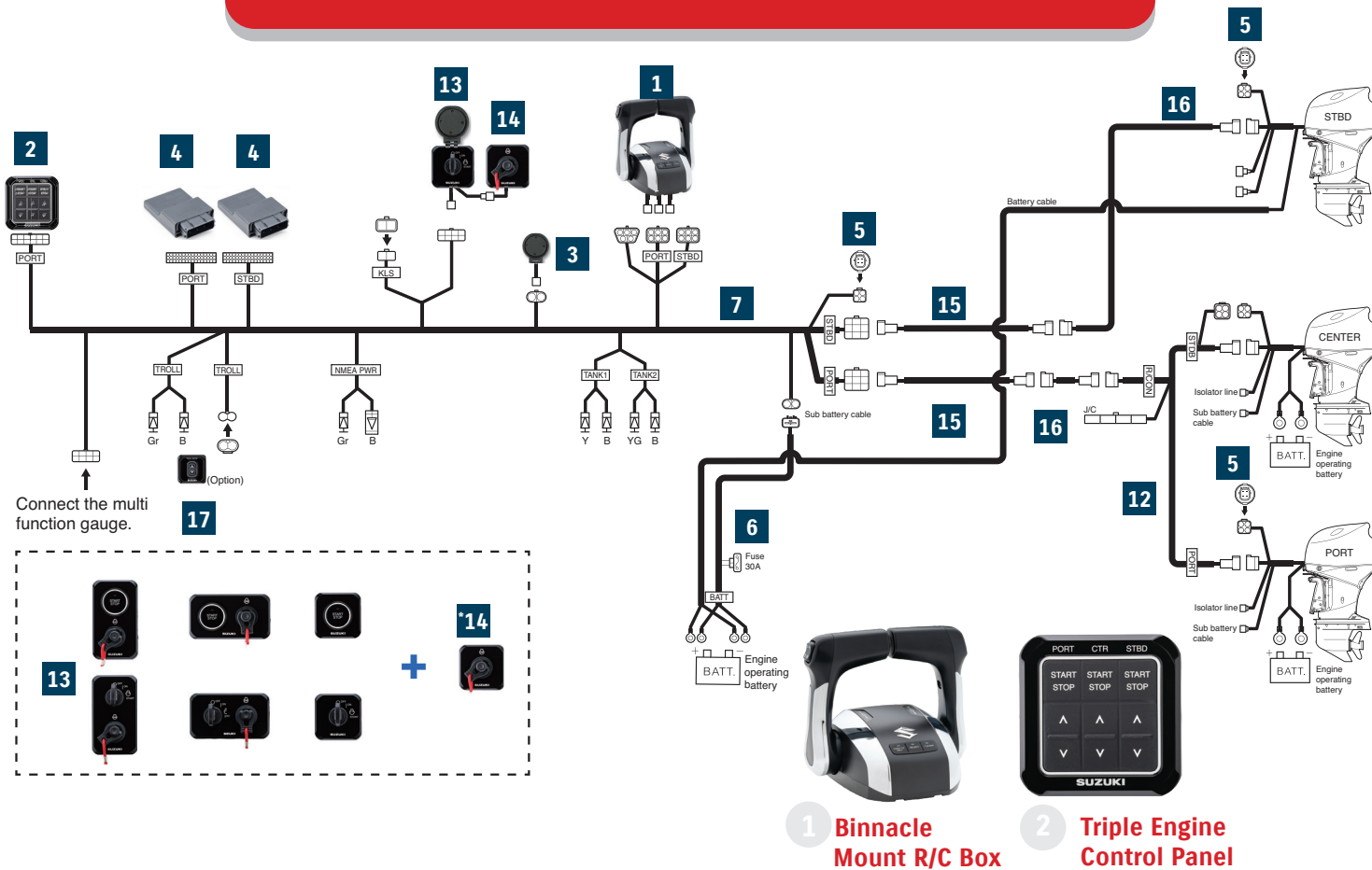

# QUAD ENGINE S.P.C. 2.0 CONTROL KITS

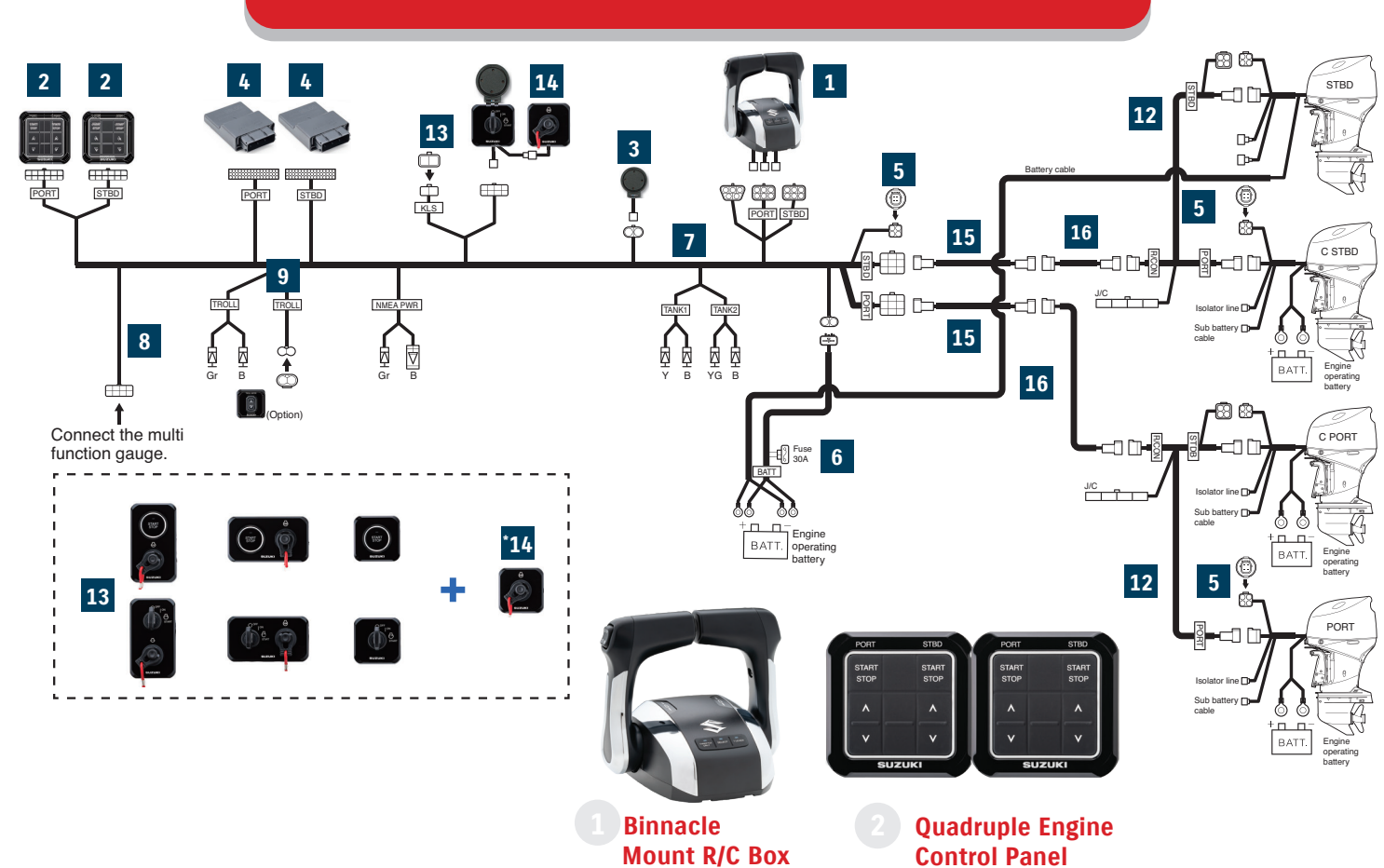

## TRIPLE ENGINE S.P.C. 2.0 CONTROL KITS

	67000-98L32 1st Station Kit	67000-98LD1 2nd Station Kit		
1	67200-98L10	Binnacle Remote Control Box	1	1
2	37120-98L10	Control Panel	1	1
3	38500-93J90	Warning Buzzer	1	2
	09407-08401	Warning Buzzer Clamp	1	2
4	36770-98L02	Boat Control Module (BCM)	2	2
	36775-98L00	BCM Holder (L)	2	2
	36776-98L00	BCM Holder (R)	2	2
	33925-98L00	BCM Cushion	2	2
5	33926-98L00	Terminal Resistor	3	-
6	36625-98J10	Battery - Lead	1	-
7	36623-98L30	BCM # 1 Wiring Harness	1	-
10	36622-98L00	Dual - Station Wiring Harness	-	1
11	36624-98L10	BCM #2 Wiring Harness	-	1
12	36621-98L00	Engine Wiring Harness	1	-
-	09403-13402	Harness Clamp	18	10
-	36612-98J20	Counter Rotation Adapter	1	-
13A*	37100-98L00	Modular Ignition Switch	Choose 1*	
	37100-98L10	Vertical Ignition Switch		
	37100-98L20	Horizontal Ignition Switch		
13B*	37290-98L00	Modular Push Button Ignition	Choose 1**	
	37290-98L10	Vertical Push Button Ignition		
	37290-98L20	Horizontal Push Button Ignition		
14***	37803-98L00	Modular Emergency Switch	1***	1***
	36620-98L00	21' Main Wiring Harness	Select required length, 2 required	Select required length, 2 required
15	36620-98L10	31' Main Wiring Harness		
16	36620-98L20	6.5' Main Harness Extension		Select if necessary
17	37860-98L00	Troll Mode Switch		Optional
18	36627-98L00	R/C Extension Harness		Select if necessary
19	36627-98L20	CAN Extension Harness		Select if necessary

\*Switch panels are sold separately, select type  
\*\*Push button ignition switches for 2nd station only  
\*\*\* Required when using 37100-98L00 or 37290-98L00

Single Station wiring diagram above is for reference only, please refer to your engine set up manual for complete setup instructions

## QUADRUPLE ENGINE S.P.C. 2.0 CONTROL KITS

	67000-98L42 1st Station Kit	67000-98LE2 2nd Station Kit		
1	67200-98L10	Binnacle Remote Control Box	1	1
2	37120-98L20	Control Panel Port	1	1
	37120-98L30	Control Panel STBD	1	1
3	38500-93J90	Warning Buzzer	1	2
4	09407-08401	Warning Buzzer Clamp	1	2
	36770-98L02	Boat Control Module	2	2
	36775-98L00	BCM Holder (L)	2	2
	36776-98L00	BCM Holder (R)	2	2
	33925-98L00	BCM Cushion	2	2
5	33926-98L00	Terminal Resistor	3	-
6	36625-98J10	Battery - Lead	1	-
7	36623-98L40	BCM # 1 Wiring Harness	1	-
10	36622-98L00	Dual - Station Wiring Harness	-	1
11	36624-98L20	BCM #2 Wiring Harness	-	1
12	36621-98L00	Engine Wiring Harness	2	-
-	09403-13402	Harness Clamp	20	15
-	36612-98J20	Counter Rotation Adapter	2	-
13A*	37100-98L00	Modular Ignition Switch	Choose 1*	
	37100-98L10	Vertical Ignition Switch		
	37100-98L20	Horizontal Ignition Switch		
13B*	37290-98L00	Modular Push Button Ignition	Choose 1**	
	37290-98L10	Vertical Push Button Ignition		
	37290-98L20	Horizontal Push Button Ignition		
14***	37803-98L00	Modular Emergency Switch	1***	1***
	36620-98L00	21' Main Wiring Harness	Select required length, 2 required	Select required length, 2 required
15	36620-98L10	31' Main Wiring Harness		
16	36620-98L20	6.5' Main Harness Extension		Select if necessary
17	37860-98L00	Troll Mode Switch		Optional
18	36627-98L00	R/C Extension Harness		Select if necessary
19	36627-98L20	CAN Extension Harness		Select if necessary

\*Switch panels are sold separately, select type  
\*\*Push button ignition switches for 2nd station only  
\*\*\* Required when using 37100-98L00 or 37290-98L00

Single Station wiring diagram above is for reference only, please refer to your engine set up manual for complete setup instructions

# SUZUKI PRECISION CONTROL 2.0

First and second station ignition switches. Featuring a gloss black face with concealed screws for a cleaner and more luxurious finish.

For DF115BG/140BG/150AP/175AP/200AP/250AP/250ATSS/300AP/300B/350A.

## 1ST STATION KEYED IGNITION SWITCHES

<b>37100-98L00</b>	Modular Keyed Ignition
<b>37100-98L10</b>	Vertical Keyed Ignition w/ Emergency Stop
<b>37100-98L20</b>	Horizontal Keyed Ignition w/ Emergency Stop



## MODULAR EMERGENCY STOP

<b>37803-98L00</b>	Required with keyed or push button modular ignition switch
--------------------	--



## 2ND STATION PUSH BUTTON IGNITION SWITCHES

<b>37290-98L00</b>	Modular Push Button Ignition
<b>37290-98L10</b>	Vertical Push Button Ignition w/ Emergency Stop
<b>37290-98L20</b>	Horizontal Push Button Ignition w/ Emergency Stop

## KEYLESS START SYSTEM

<b>37105-98L10</b>	Keyless Kit, Push button switch required
--------------------	--



## CONTROL PANELS

<b>37120-98L00</b>	Dual Engine Control Panel (Pictured)
<b>37120-98L10</b>	Triple Engine Control Panel
<b>37120-98L20</b>	Quad Control Panel - Port
<b>37120-98L30</b>	Quad Control Panel - Starboard



## Main Wiring Harnesses

Main Wiring Harness. Order length as needed for rigging applications.

## Battery Sub-Lead

For use with SPC / Digital Models.

<b>36625-98J10</b>	7' (2.2m)
<b>36625-98J20</b>	20' (6.1m)



## Battery Isolator Lead Sets

Used for charging auxiliary battery.

<b>33830-98J02</b>	DF300 2007-2011 only
<b>33830-98J11</b>	DF150A/175A/200A/150AP/175AP/200AP/300AP/350A



## Replacement Engine Wiring Harness

<b>36621-98L00</b>	Triple and Quadruple Engine Wiring Harness
--------------------	--



<b>36620-98L00</b>	21' (6.5m) Wiring Harness
<b>36620-98L10</b>	31' (9.5m) Wiring Harness
<b>36620-98L20</b>	6.5' (2m) Wiring Harness Extension (Optional; order as needed)



## BCM Harness

<b>36623-98L00</b>	BCM Harness No. 1 for Single Engine, First Station
<b>36623-98L30</b>	BCM Harness No. 1 for Dual or Triple Engine, First Station
<b>36624-98L00</b>	BCM Harness No. 2 for Single Engine, Second Station
<b>36624-98L10</b>	BCM Harness No. 2 for Dual or Triple Engine, Second Station
<b>36623-98L40</b>	BCM Harness No. 1 for Quadruple Engine, First Station
<b>36624-98L20</b>	BCM Harness No. 2 for Quadruple Engine, Second Station

# DIGITAL INSTRUMENTATION

## Multi-Function Gauge – SMG4

When you're on the water, it's vital that you can get the information you need about your engine's condition and performance whenever you need it. That's exactly the thinking behind our Suzuki Multi-Function Gauge.

### ANALOG TACHOMETER & SPEED MODE



\* Speed sensor or GPS module will be required in order to display the speed.

### DIGITAL TACHOMETER MODE



- Fuel flow (instantaneous)
- Mileage (instantaneous and average)
- Trip time, Trip distance

### All the Information in One Place

This brilliantly simple technology gives you the right information at the right time, all on one user friendly, highly intuitive screen. You can view a wide range of important information including engine RPM, speed, trim angle, engine temp, and fuel economy. You'll also receive alerts from the engine's sensors and warning systems. All you need for effortless and relaxing boating in one simple, reassuring, and reliable device.

### DIGITAL TACHOMETER & SPEED



### ANALOG TACHOMETER & SPEED



### ANALOG SPEED (NIGHT)



### FUEL MODE



### TROLL MODE



## FEATURES

### MULTILINGUAL MENU



SMG4 is now available in 13 languages.

### AUTOMATIC TRIM



Automatically adjusts trim based on engine RPM

### DEMO MODE



Pre-installed data demonstrates gauge functionality. Great for boat shows!

# DIAGNOSTIC MOBILE APP

## New Advanced Service Tool

Our new Suzuki Diagnostic App lets you send your Suzuki Authorized Dealer information they can use to service and maintain your outboard instantly and easily.

## How It Works

1. The outboard sends engine data and converts it into a QR code displayed on the Multi-Function Gauge or Multi-Function Display.



2. With the SDS Mobile App, you can then scan the QR code on the Multi-Function Gauge or Multi-Function Display with your phone. The engine data will be stored on your smart phone.



3. You can then send the engine data via email to your Suzuki Dealer.



### DOWNLOAD THE APP FROM



Apple and Apple logo are trademarks of Apple Inc., registered in the U.S. and other countries. App Store is a service mark of Apple Inc., registered in the U.S. and other countries.



Google Play and the Google Play logo are trademarks of Google LLC. SDS Mobile App and Email Service is entirely free of charge



SDS Mobile works in tandem with our new Multi-Function Gauge and new Multi-Function Display. Simply download the App, available on iOS and Android™, to your smartphone: you don't need a separate device.

When you email your QR code to the dealer, the data will be transferred directly - including engine serial number, number of hours since last oil change, and total hours of operation at different RPM.

iOS is a registered trademark or trademark of Cisco Systems, Inc. and/or its affiliates in the United States and certain other countries. Android is a trademark of Google LLC.

# SUZUKI MULTIFUNCTION GAUGE ACCESSORIES & KIT CONTENTS LIST

## NMEA 2000 Cable Kit

This cable kit includes parts needed to make a basic NMEA 2000 backbone. A backbone is required for speed data to be displayed on SMG using either a GPS antenna or paddle wheel transducer. Kit contents in table below.

**990C0-88L00-KIT**

NMEA 2000 Backbone Cable Kit			
	Part Number	Part Name	990C0-88L00-KIT
4	990C0-88104	2' N2K Cable	1
5	990C0-88112	N2K Power Cable / T	1
6	990C0-88110	Backbone T	1
7	990C0-88113	Terminator (F)	1
8	990C0-88114	Terminator (M)	1

## SMG Sun Cover

Replacement white plastic cover for SMG.

**34211-96L00**



## Single and Dual Mechanical Engine SMG Requirements

See below chart for required SMG components for dual mechanical engines. Please order components separately.

Components Chart - Single and Dual Mechanical Engines			Single Engine	Dual Engine
1	34011-96L44	Suzuki Multifunction Gauge (SMG)	1	2
2	36665-87L10	Mechanical Engine Adapter	-	1
4	990C0-88104	2' Backbone Cable	-	2
5	990C0-88112	Power Cable	-	1
6	990C0-88110	Backbone T	-	2
7	990C0-88113	Female Terminator	-	1
8	990C0-88114	Male Terminator	-	1
11	36661-96L30	Mech Gauge Adapter	1	2

## COMPONENTS LIST

1	Multifunction Gauge	2	Mechanical Multi Engine Adapter	3	Extension Wire	1	34011-96L44	Multifunction Gauge
						2	36665-87L10	Mechanical Multi Engine Adapter
						3	36682-92E00	Extension wire
						4	990C0-88104	2' N2K Cable
							990C0-88105	6' N2K Cable
							990C0-88107	15' N2K Cable
							990C0-88108	25' N2K Cable
						5	990C0-88112	N2K Power Cable / T
						6	990C0-88110	Backbone T
						7	990C0-88113	Terminator (F)
						8	990C0-88114	Terminator (M)
							990C0-88104	2' N2K Cable
							990C0-88105	6' N2K Cable
						9	990C0-88107	15' N2K Cable
							990C0-88108	25' N2K Cable
						10	36666-96L00	Gauge Power Adapter (dual station)
							36661-96L20	Gauge Adapter (SPC 1.0 Only)
						11	36661-96L30	Gauge Adapter (Mechanical Engines)
						12a	36667-96L00	Gauge Adapter (SPC 2,3,4)
						12b	36667-96L30	Gauge Adapter for tanks 3-4
						13a	990C0-88317	Paddle Wheel / Speed Sensor
						13b	990C0-88122	GPS Antenna w/ Compass
						14	36667-96L11	2nd Gauge Adapter
						15	36665-96L00	Dual Station Adapter
						16	36667-96L20	Extension wire
						17	36660-89L02	Adapter for use with DF9.9B - DF30A



# SUZUKI SINGLE MECHANICAL ENGINE

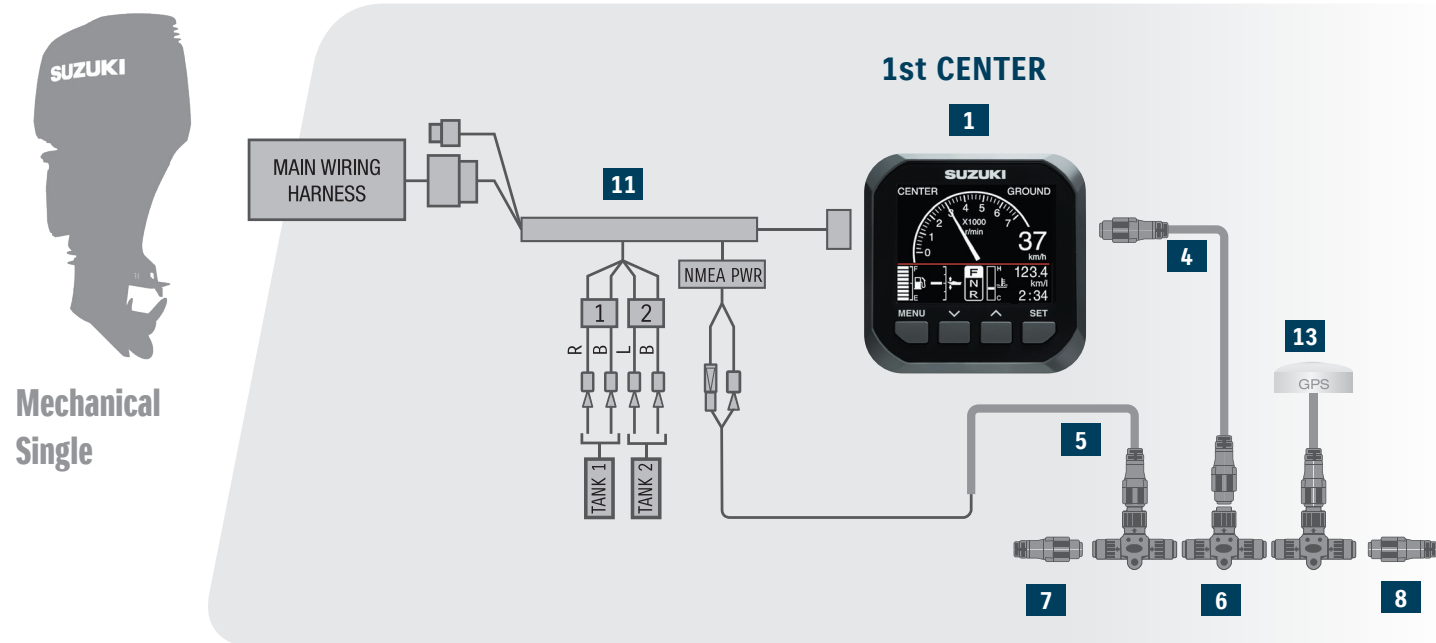

Mechanical Single

## Single Mechanical Engine

Order SMG and SMG Mechanical Adapter for single mechanical engine applications.

<b>34011-96L44</b>	Suzuki Multifunction Gauge (SMG)
<b>36661-96L30</b>	Mechanical Engine Adapter

## NMEA 2000 Cable Kit

This NMEA 2000 Cable Kit includes the basics for what you need to make a NMEA 2000 backbone in your electronics system. A backbone is required for speed data (optional) to be shown on the Suzuki Multifunction Displays. Speed sources listed below. See page 17 for required components.

**990C0-88L00-KIT**

## Speed Data Sources (Optional)

SMG must have a speed source to display speed data. This can be achieved by adding a GPS antenna or paddle wheel transducer to the backbone if no other speed source is available. Simply use the included N2K Tee to extend your backbone and plug it in! (GPS option shown in diagram)

<b>990C0-88122</b>	GPS Antenna	<b>990C0-88317</b>	Paddle Wheel
--------------------	-------------	--------------------	--------------

# SUZUKI DUAL MECHANICAL ENGINES

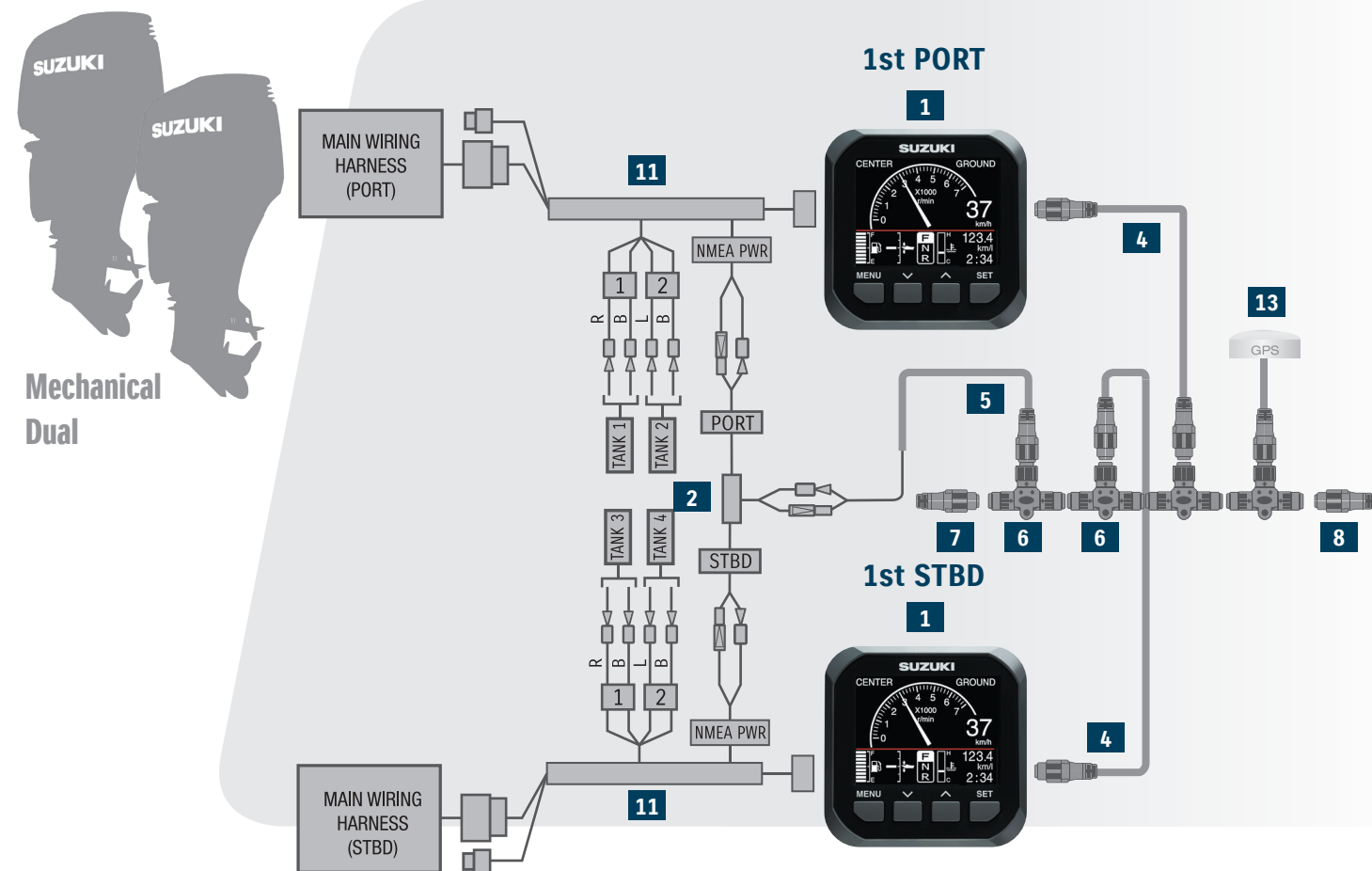

Mechanical Dual

## Dual Mechanical Engines

Order following components separately if using SMG's with dual mechanical engines.

No.	Req.
<b>1</b>	<b>34011-96L44</b> Suzuki Multifunction Gauge 2
<b>2</b>	<b>36665-87L10</b> Mechanical Multi Engine Adapter 1
<b>4</b>	<b>990C0-88104</b> 2' Backbone Cable 2
<b>5</b>	<b>990C0-88112</b> N2K Power Cable 1
<b>6</b>	<b>990C0-88110</b> Backbone T 2
<b>7</b>	<b>990C0-88113</b> Female Terminator 1
<b>8</b>	<b>990C0-88114</b> Male Terminator 1
<b>11</b>	<b>36661-96L30</b> Mechanical Gauge Adapter 2

## NMEA 2000 Cable Kit\*

This NMEA 2000 Cable Kit includes the basics for what you need to make a NMEA 2000 backbone in your electronics system. A backbone is required for speed data (optional) to be shown on the Suzuki Multifunction Displays. Speed sources listed below. See page 17 for required components.

**990C0-88L00-KIT**

## Speed Data Sources (Optional)

SMG must have a speed source to display speed data. This can be achieved by adding a GPS antenna or paddle wheel transducer to the backbone if no other speed source is available. Simply use the included N2K Tee to extend your backbone and plug it in! (GPS option shown in diagram)

<b>990C0-88122</b>	GPS Antenna	<b>990C0-88317</b>	Paddle Wheel
--------------------	-------------	--------------------	--------------

# SUZUKI PRECISION CONTROL 2.0 SINGLE

# SUZUKI PRECISION CONTROL 2.0 DUAL

## SINGLE ENGINE - SINGLE STATION

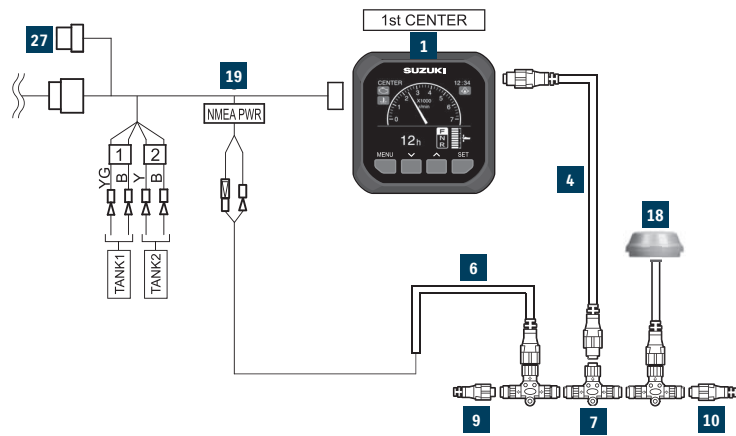

## SINGLE ENGINE - DUAL STATION

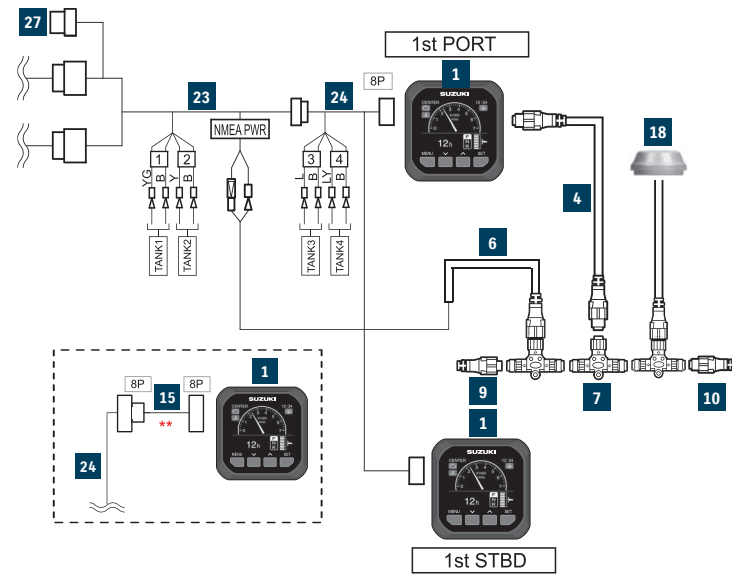

## DUAL ENGINES - SINGLE STATION

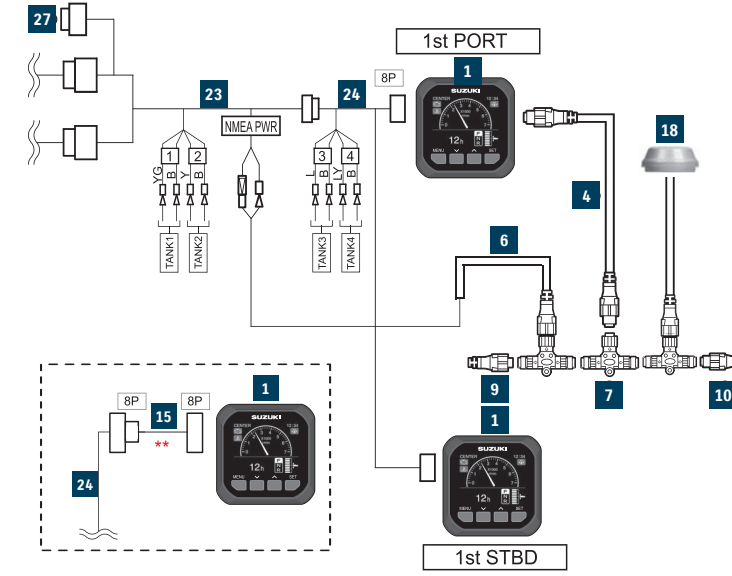

## DUAL ENGINES - DUAL STATION

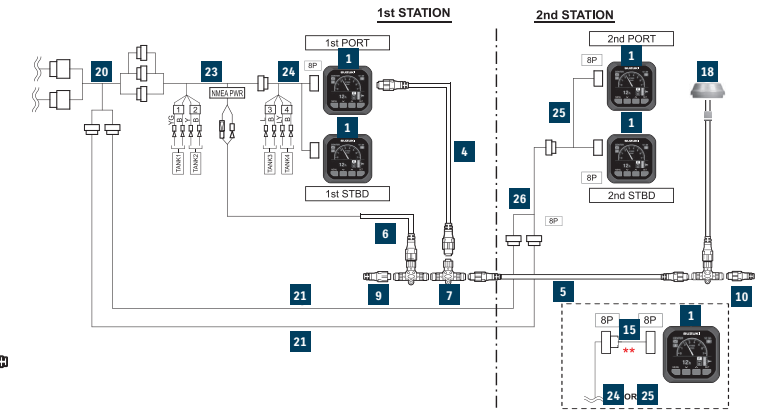

Connecting an SMG to SPC 2.0 is now easier than ever! SMG now plugs directly in to the BCM harness, eliminating the need for an extra adapter harness. As an option, if you also require speed data to be displayed, also purchase a NMEA2000 (N2K) starter kit and a speed source.

No.	Part Name	Part Number	Qty.	
1	Suzuki Multifunction Gauge	34011-96L44	1	SMG directly plugs in to BCM Harness
4	2' N2K Cable	990C0-88L00-KIT*	1	Part number 990C0-88104, included in N2K Kit
6	N2K Power Cable			Part number 990C0-88112, included in N2K Kit
7	N2K Tee			Part Number 990C0-88110, included in N2K Kit
9	Terminator (F)			Part number 990C0-88113, included in N2K Kit
10	Terminator (M)			Part number 990C0-88114, included in N2K Kit
18	Paddle Wheel Sensor GPS Module (Pictured)			990C0-88317 990C0-88122
19	BCM Harness #1	36623-98L00	-	Included in SPC 2.0 Control Kits
27	Terminal Resistor	33926-98L00	-	Included in SPC 2.0 Control Kits

No.	Part Name	Part Number	Qty.	
1	Suzuki Multifunction Gauge	34011-96L44	2	SMG directly plugs in to BCM Harness
4	2' N2K Cable	990C0-88L00-KIT*	1	Part number 990C0-88104, included in N2K Kit
6	N2K Power Cable			Part number 990C0-88112, included in N2K Kit
7	N2K Tee			Part Number 990C0-88110, included in N2K Kit
9	Terminator (F)			Part number 990C0-88113, included in N2K Kit
10	Terminator (M)			Part number 990C0-88114, included in N2K Kit
5	15' N2K Cable 25' N2K Cable			990C0-88107 990C0-88108
18	Paddle Wheel Sensor GPS Module (Pictured)	990C0-88317 990C0-88122	1	Choose Either (Optional, only if speed data is required)
19	BCM Harness #1	36623-98L00	-	Included in SPC 2.0 Control Kits
27	Terminal Resistor	33926-98L00	-	Included in SPC 2.0 Control Kits

\*Only required if adding a speed source

\*Only required if adding a speed source

No.	Part Name	Part Number	Qty.	
1	Suzuki Multifunction Gauge	34011-96L44	2	SMG directly plugs in to BCM Harness
4	2' N2K Cable	990C0-88L00-KIT*	1	Part number 990C0-88104, included in N2K Kit
6	N2K Power Cable			Part number 990C0-88112, included in N2K Kit
7	N2K Tee			Part Number 990C0-88110, included in N2K Kit
9	Terminator (F)			Part number 990C0-88113, included in N2K Kit
10	Terminator (M)			Part number 990C0-88114, included in N2K Kit
15	2' Gauge Extension			36667-96L60
18	Paddle Wheel Sensor GPS Module (Pictured)	990C0-88317 990C0-88122	1	Choose Either (Optional, only if speed data is required)
23	BCM Harness #1, Multi-Engine	36623-98L30	-	Included in SPC 2.0 Control Kits
24	Multi-Gauge Adapter**	36667-96L50 36667-96L40	1	Same as below, but has connections for tanks 3 and 4 Used to Connect Multiple SMG's
27	Terminal Resistor	33926-98L00	-	Included in SPC 2.0 Control Kits

\*Only required if adding a speed source

No.	Part Name	Part Number	Qty.	
1	Suzuki Multifunction Gauge	34011-96L44	4	SMG directly plugs in to BCM Harness
4	2' N2K Cable	990C0-88L00-KIT*	1	Part number 990C0-88104, included in N2K Kit
6	N2K Power Cable			Part number 990C0-88112, included in N2K Kit
7	N2K Tee			Part Number 990C0-88110, included in N2K Kit
9	Terminator (F)			Part number 990C0-88113, included in N2K Kit
10	Terminator (M)			Part number 990C0-88114, included in N2K Kit
5	15' N2K Cable 25' N2K Cable			990C0-88107 990C0-88108
15	2' Gauge Extension	36667-96L60	1	Optional, only use if necessary
18	Paddle Wheel Sensor GPS Module (Pictured)	990C0-88317 990C0-88122	1	Choose Either (Optional, only if speed data is required)
20	2nd Station Main Harness	36622-98L00	-	Included in SPC 2.0 Control Kits
21	21' Main Harness 31' Main Harness	36620-98L00 36620-98L10	-	For illustration purposes only
23	BCM Harness #1, Multi-Engine	36623-98L30	-	Included in SPC 2.0 Control Kits
24	Multi-Gauge Adapter**	36667-96L50	1	Same as below, but has connections for tanks 3 and 4
25	Multi-Gauge Adapter**	36667-96L40	1	Used to Connect Multiple SMG's
26	BCM Harness #2, Multi-Engine	36624-98L10	-	Included in SPC 2.0 Control Kits

\*Only required if adding a speed source

\*\*Can use 1 x 36667-96L40 + 1 x 36667-96L50, or 2 x 36667-96L40 if tanks 3 and 4 not required

## Speed Data Sources (Optional)

SMG must have a speed source to display speed data. This can be achieved by adding a GPS antenna or paddle wheel transducer to the backbone if no other speed source is available. Simply use the included N2K Tee to extend your backbone and plug it in! (GPS option shown in diagram)

990C0-88122	GPS Antenna	990C0-88317	Paddle Wheel
-------------	-------------	-------------	--------------

\*See page 17 for kit parts lists with corresponding diagram reference numbers

# SUZUKI PRECISION CONTROL 2.0 TRIPLE

# SUZUKI PRECISION CONTROL 2.0 QUADRUPLE

## TRIPLE ENGINE - SINGLE STATION

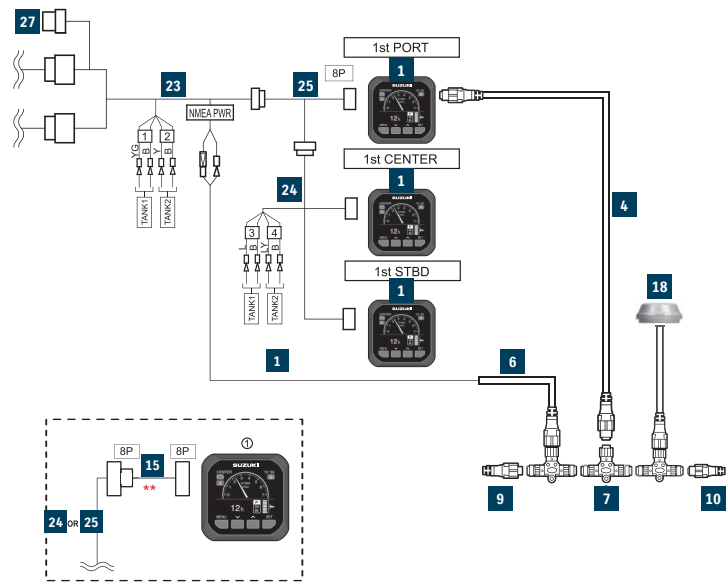

## TRIPLE ENGINE - DUAL STATION

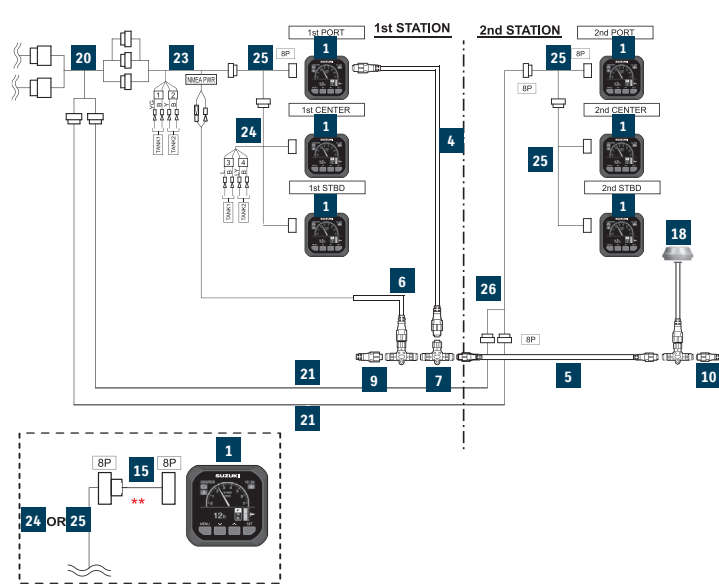

## QUADRUPLE ENGINE - SINGLE STATION

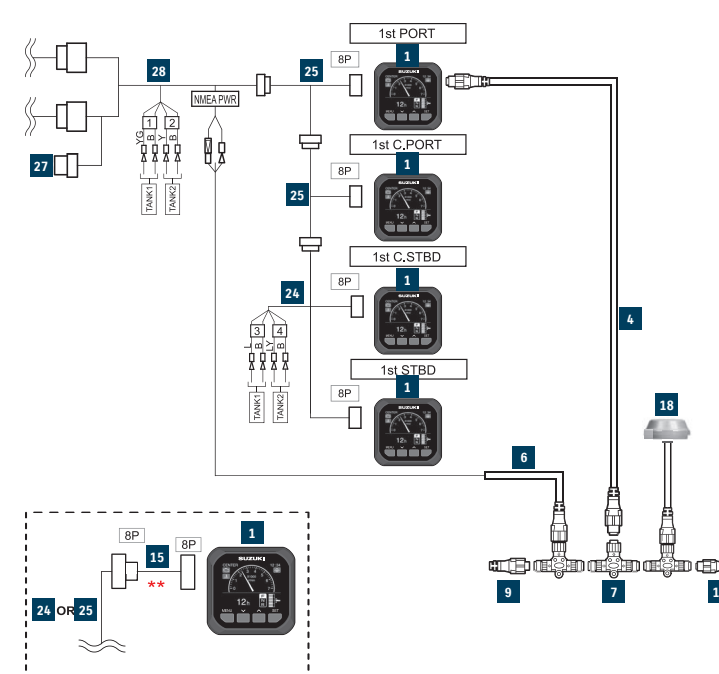

## QUADRUPLE ENGINE - DUAL STATION

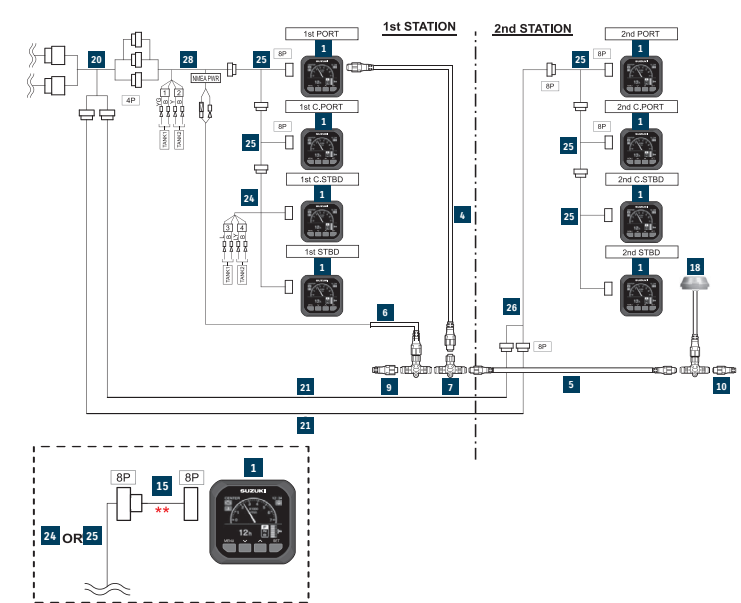

No.	Part Name	Part Number	Qty.	
1	Suzuki Multifunction Gauge	34011-96L44	3	SMG directly plugs in to BCM Harness
4	2' N2K Cable	990C0-88L00-KIT*	1	Part number 990C0-88104, included in N2K Kit
6	N2K Power Cable			Part number 990C0-88112, included in N2K Kit
7	N2K Tee			Part Number 990C0-88110, included in N2K Kit
9	Terminator (F)			Part number 990C0-88113, included in N2K Kit
10	Terminator (M)			Part number 990C0-88114, included in N2K Kit
15	2' Gauge Extension			36667-96L60
18	Paddle Wheel Sensor	990C0-88317	1	Choose Either (Optional, only if speed data is required)
18	GPS Module (Pictured)	990C0-88122		
23	BCM Harness #1, Multi-Engine	36623-98L30	-	Included in SPC 2.0 Control Kits
24	Multi-Gauge Adapter**	36667-96L50	1	Same as above, but has connections for tanks 3 and 4
25		36667-96L40	1	Used to Connect Multiple SMG's
27	Terminal Resistor	33926-98L00	-	Included in SPC 2.0 Control Kits

\*Only required if adding a speed source

\*\*Can use 1 x 36667-96L40 + 1 x 36667-96L50, or 2 x 36667-96L40 if tanks 3 and 4 not required

No.	Part Name	Part Number	Qty.	
1	Suzuki Multifunction Gauge	34011-96L44	6	SMG directly plugs in to BCM Harness
4	2' N2K Cable	990C0-88L00-KIT*	1	Part number 990C0-88104, included in N2K Kit
6	N2K Power Cable			Part number 990C0-88112, included in N2K Kit
7	N2K Tee			Part Number 990C0-88110, included in N2K Kit
9	Terminator (F)			Part number 990C0-88113, included in N2K Kit
10	Terminator (M)			Part number 990C0-88114, included in N2K Kit
5	15' N2K Cable			990C0-88107
5	25' N2K Cable	990C0-88108		
15	2' Gauge Extension	36667-96L60	1	Optional, only use if necessary
18	Paddle Wheel Sensor	990C0-88317	1	Choose Either (Optional, only if speed data is required)
18	GPS Module (Pictured)	990C0-88122		
20	2nd Station Main Harness	36622-98L00	-	Included in SPC 2.0 Control Kits
21	21' Main Harness	36620-98L00	-	For illustration purposes only
21	31' Main Harness	36620-98L10		
23	BCM Harness #1, Multi-Engine	36623-98L30	-	Included in SPC 2.0 Control Kits
24	Multi-Gauge Adapter**	36667-96L50	1	Same as above, but has connections for tanks 3 and 4
25		36667-96L40	3	Used to Connect Multiple SMG's
26	BCM Harness #2, Multi-Engine	36624-98L10	-	Included in SPC 2.0 Control Kits

\*Only required if adding a speed source

\*\*Can use 3 x 36667-96L40 + 1 x 36667-96L50, or 4 x 36667-96L40 if tanks 3 and 4 not required

No.	Part Name	Part Number	Qty.	
1	Suzuki Multifunction Gauge	34011-96L44	4	SMG directly plugs in to BCM Harness
4	2' N2K Cable	990C0-88L00-KIT*	1	Part number 990C0-88104, included in N2K Kit
6	N2K Power Cable			Part number 990C0-88112, included in N2K Kit
7	N2K Tee			Part Number 990C0-88110, included in N2K Kit
9	Terminator (F)			Part number 990C0-88113, included in N2K Kit
10	Terminator (M)			Part number 990C0-88114, included in N2K Kit
15	2' Gauge Extension			36667-96L60
18	Paddle Wheel Sensor	990C0-88317	1	Choose Either (Optional, only if speed data is required)
18	GPS Module (Pictured)	990C0-88122		
24	Multi-Gauge Adapter**	36667-96L50	1	Same as above, but has connections for tanks 3 and 4
25		36667-96L40	2	Used to Connect Multiple SMG's
27	Terminal Resistor	33926-98L00	-	Included in SPC 2.0 Control Kits
28	BCM Harness #1, Quadruple	36623-98L40	-	Included in SPC 2.0 Control Kits

\*Only required if adding a speed source

\*\*Can use 2 x 36667-96L40 + 1 x 36667-96L50, or 3 x 36667-96L40 if tanks 3 and 4 not required

No.	Part Name	Part Number	Qty.	
1	Suzuki Multifunction Gauge	34011-96L44	8	SMG directly plugs in to BCM Harness
4	2' N2K Cable	990C0-88L00-KIT*	1	Part number 990C0-88104, included in N2K Kit
6	N2K Power Cable			Part number 990C0-88112, included in N2K Kit
7	N2K Tee			Part Number 990C0-88110, included in N2K Kit
9	Terminator (F)			Part number 990C0-88113, included in N2K Kit
10	Terminator (M)			Part number 990C0-88114, included in N2K Kit
5	15' N2K Cable			990C0-88107
5	25' N2K Cable	990C0-88108		
15	2' Gauge Extension	36667-96L60	1	Optional, only use if necessary
18	Paddle Wheel Sensor	990C0-88317	1	Choose Either (Optional, only if speed data is required)
18	GPS Module (Pictured)	990C0-88122		
20	2nd Station Main Harness	36622-98L00	-	Included in SPC 2.0 Control Kits
21	21' Main Harness	36620-98L00	-	For illustration purposes only
21	31' Main Harness	36620-98L10		
24	Multi-Gauge Adapter**	36667-96L50	1	Same as above, but has connections for tanks 3 and 4
25		36667-96L40	5	Used to Connect Multiple SMG's
26	BCM Harness #2, Quadruple	36624-98L20	-	Included in SPC 2.0 Control Kits
28	BCM Harness #1, Quadruple	36623-98L40	-	Included in SPC 2.0 Control Kits

\*Only required if adding a speed source

\*\*Can use 2 x 36667-96L40 + 1 x 36667-96L50, or 3 x 36667-96L40 if tanks 3 and 4 not required

# SUZUKI MULTI-FUNCTION DISPLAY



## Suzuki Multi-Function Display Connected to Earth

The Suzuki Multi-Function Display and its features offers you access to all the information you need for The Ultimate boating experience. Control at the touch of a finger with the touch screen glass top design, available in 12" and 16" sizes.

### Key Benefits:

The Suzuki Multi-Function Display gives you access to all of your Suzuki engine information, so you can easily and quickly see the performance of your outboard(s) in one clear view. Additional features include chartplotting, sounder, radar, and weather. Detailed cartography chip not included. Transducers, radar antennas, and weather antennas must be purchased from your local Furuno dealer. Additional charge to unlock radar and sounder functions on 12" and 16" models, unlock codes can be purchased from your local Furuno dealer.



## Suzuki Multi-Function Display - SMD7 and SMD9

Powerful Technology in a compact design that is compact enough to fit on small runabouts and center consoles. The 7" and 9" touch screens enable you to operate the chartplotter with built-in fish finder at the touch of a finger.



Part Number	Description	Notes
<b>990C0-34901-007</b>	SMD 7" Kit	Gateway not included, need engine engine adapter (Mech or SPC)*
<b>990C0-34901-009</b>	SMD 9" Kit	Gateway not included, need engine engine adapter (Mech or SPC)*
<b>34900-98L22</b>	SMD 12"	Requires gateway (1 per engine) and engine adapter, see below
<b>34900-98L31</b>	SMD 16"	Requires gateway (1 per engine) and engine adapter, see below
<b>34923-96L02</b>	SMD Gateway	For SPC 1.0 and Mechanical Models 2022 and prior **
<b>34923-96L13</b>	SMD Gateway	For SPC 2.0 Single Engine Applications ***
<b>36661-96L30</b>	Mechanical Engine Adapter	Required for all mechanical engine installs, 1 per engine
<b>36661-96L20</b>	SPC Engine Adapter	SPC 1.0 - 1-3 engine configs require 1 adapter, 4 engine configs require 2
<b>36667-96L00</b>	SPC Multi Engine Adapter	SPC 1.0 - 2-3 engine configs require 1 adapter, 4 engine configs require 2

\* Must order gateway separately \*\* Each engine requires 1 gateway \*\*\* Can be programmed for up-to 6 engines

# SUZUKI C-10 & NMEA 2000 ACCESSORIES PARTS LIST



The Suzuki Color Display is a LED high-resolution screen that has very sharp, crisp lines and is extremely easy to read. It has a bonded glass front screen so whether it be sun, salt, or UV rays, your screen will never blur or fade like a plastic cover. The C-10 has its mounting points in the front so there is no need to crawl under your console to mount it. There is one easy connection to Suzuki's digital harness. Save your favorite programming and update the display using the Mini USB port. The C-10 is able to monitor functions such as RPM, Speed\*, Water Pressure\*, Fuel Level\*, Fuel Consumption, Coolant Temperature, Oil Level, Oil Temperature, Trim Level, Hours, or Volts. The C-10 is able to monitor up to 2 engines simultaneously. The Suzuki C-10 can be retro-fitted, to replace a 4" round gauge. (\* additional sensors required)

## Suzuki Color Display Kit

**990C0-04C10-KIT**  
Suzuki Color Display Kit includes:

Part Number	Description	Qty
<b>990C0-04C10</b>	Suzuki Color Display	1
<b>990C0-88114</b>	Male Terminator	1
<b>990C0-88113</b>	Female Terminator	1
<b>990C0-88110</b>	NMEA "T"	2
<b>990C0-88112</b>	Power Cable + Network T	1
<b>990C0-88149-357</b>	Interface Cable	1

## How It Works

- Bright, full color 320 x 240 LED screen makes it easier to see menus and screen detail in both full sunlight and night operation
- Fits standard 3-3/8" gauge cutout
- Each C-10 gauge will display engine info from 1 or 2 engines
- Preconfigured pages or create your own
- Micro USB for software updates (update cable required)
- Power and data through single NMEA 2000 micro-C connector
- Low profile front mount – 8 mm of dash (rear mount option for "glass dash" installations)

## Suzuki C-10 Cover

This cover protects the Suzuki Color Display (C-10) from the elements. Use the cover to extend the life of your Suzuki C-10 Color Gauges.



<b>990C0-10C10</b>	Suzuki C10 Cover
--------------------	------------------

## Suzuki Engine Connect Gateway

The Suzuki Engine Connect Gateway provides Suzuki engine information, diagnostic codes and proprietary pop-up messages on compatible Simrad and Lowrance Multi-Function display (MFD) units.

**Note:** Do not utilize C10 gauges with the Suzuki Connect Gateway. Only one Suzuki Connect Gateway is required per vessel. In multiple engine applications, each additional engine will require a standard Suzuki engine interface."

<b>990C0-88171</b>	Suzuki Connect Gateway
--------------------	------------------------

## SENSORS



### GPS Antenna with Compass

Suzuki has upgraded its GPS Antenna to include compass heading.

<b>990C0-88122</b>	GPS Antenna with Compass Heading
--------------------	----------------------------------

### Fluid Level Sensor

Monitors fluid levels such as fuel, live well water level, etc. 10 ft. cable.

<b>990C0-88217</b>	Fluid Level Sensor
--------------------	--------------------

### Speed Sensor

Paddle wheel-type speed sensor. 10 ft. cable.

<b>990C0-88317</b>	Speed Wheel
--------------------	-------------

### Temperature Sensor

Surface Water Temperature sensor. 10 ft. cable.

<b>990C0-88318</b>	Temperature Sensor
--------------------	--------------------

## INTERFACE CABLES

### Engine Interface Cables



DF9.9B thru DF350A Suzuki Outboards can connect to the system using the exclusive Engine Interface. (Adapter Cable also needed for DF115BG/140BG/150AP/175AP/200AP/250AP/300AP/300B/350A)

<b>990C0-88149-357</b>	Software Version 3.7 (Subject to change) ~310001-Newer
<b>990C0-88149-294</b>	Software Version 2.9 (Subject to change) ~Previous ~219999
<b>990C0-99C10-CBL</b>	C10 Update Cable

## NMEA 2000 COMPONENTS

### NMEA 2000 Extension Cables



NMEA 2000 Extension Cable allows compatible sensors or other devices to be added by the use of T-Connectors throughout the system.

<b>990C0-88104</b>	2' Connection cable
<b>990C0-88105</b>	6' Connection cable
<b>990C0-88107</b>	15' Connection cable
<b>990C0-88108</b>	25' Connection cable

### Power Cable

Fused(3A) lead connects extension cable to the power source.

<b>990C0-88112</b>	Single Power Cable (Includes Network T)
--------------------	---

### Quad Power Node

Allows network to be powered from multiple power sources (key switch, accessory switch, etc.).

<b>990C0-88130</b>	Quad Power Node
--------------------	-----------------

### T-Connector

T-Connector for NMEA 2000 system.

<b>990C0-88110</b>	T-Connector
<b>990C0-88109</b>	Quad-T

### Power Isolation

The NMEA 2000 power isolator makes sure the NMEA 2000 power from the engines and system power are kept separate.

<b>990C0-88115</b>	Network Power Isolator (not shown)
--------------------	------------------------------------

### NMEA Adaptor

Used to connect a new style NMEA device net connector to an older network with Blue T's. Used to connect an early Blue Connector device to the later NMEA T.

<b>990C0-88137</b>	NMEA Device to Blue "T"
--------------------	-------------------------

### Terminating Resistors

120 ohm Terminating Resistors are required for any open cable ends in the NMEA 2000 system.

<b>990C0-88113</b>	Terminator - Female
<b>990C0-88114</b>	Terminator - Male



# MECHANICAL CONTROLS

## Single Binnacle Control Box

Single Binnacle Control Box uses a convenient thumb-operated power trim and tilt switch, push-button shifting disengagement, for faster warm-ups and built-in neutral safety switch. Main wiring harness, ignition switch, and control cable must be ordered separately, see pages 25, 30, and 31 for options.

**67200-88L02** Single Binnacle Control Box Assembly



## Flush Mount Binnacle Control Box

Suzuki's top quality Flush Mount Control Box features include a smooth action thumb-controlled power trim and tilt switch, a convenient push button to disengage transmission for throttle only, and a built-in neutral safety switch. Reversible for left hand installations. Main wiring harness, ignition switch, and control cable must be purchased separately, see pages 25, 30, and 31 for options.

**67200-93J34** Flush Mount Control Box

## Dual Binnacle Control Box

Dual Binnacle Control Box includes the same features as the Single Binnacle Control Box, plus a unique base mounted PTT system allowing you to trim the motors individually then adjust them together for maximum performance. Main wiring harness, ignition switch, and control cable must be ordered separately, see pages 25, 30, and 31 for options.

**67200-88L12** Dual Binnacle Control Box Assembly



Suzuki Genuine Control Boxes are designed for longevity and ease of use.

Choose a control box that fits your application. We offer a Single Binnacle Control Box for your top of the line Suzuki Outboard, or choose a Dual Binnacle Control Box to manage 2 Suzuki Outboards masterfully. Suzuki Genuine Control Boxes define accuracy, user-friendliness and durability.



## Side Mount Control Boxes

Side Mount Control Boxes can be tailored to your needs. Standard features include a fast idle lever for easy warm-ups, a key-type ignition switch, and an emergency stop switch. Main Wiring Harness and control cables ordered separately. See page 31 for options.

**67200-93J70** DF9.9B-DF250 Single Engine, with PTT switch

## Miscellaneous Components

<b>38500-92X50</b>	Warning Buzzer.
<b>36620-93J20</b>	Control Box Adaptor Harness. Adapts 2005+ model control box with square connector to 2004 and earlier motors with round connector.
<b>36620-93J30</b>	Control Box Adaptor Harness. Adapts 2005+ model engine with square connector to 2004 and earlier harness with round connector.



**67500-88L00** Single Binnacle Control Box Spacer

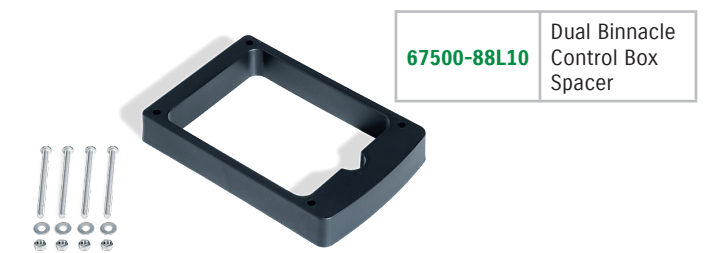

**67500-88L10** Dual Binnacle Control Box Spacer

## CAN Bus Main Wiring Harnesses

New for 2024 is the availability of a CAN Bus main harness which gives mechanically controlled Suzuki outboard engines the same access to the Autotrim and Keyless Starting features previously only available to digital Suzuki outboard engines. See chart below for engine compatibilities. For standard Analog / K-Line Main Wiring Harnesses and control cables, please see page 31.

Feature Compatibilities	Engine Model				
	DF40A-60A	DF75A-90A	DF115B-140B	DF150A-200A	DF200-250
<b>CAN Harness</b>	Yes	Yes	Yes	Yes	No
<b>Auto-Trim*</b>	No	No	Yes	Yes	No
<b>Keyless Starting</b>	No	Yes	Yes	Yes	No
<b>SMG4 Adapter**</b>	No	No	No	No	Yes
<b>36620-93JA0</b>	21.3' / 6.5m Main Harness				
<b>36620-93JB0</b>	16.4' / 5.0m Main Harness				
<b>36620-93JC0</b>	26.2' / 8.0m Main Harness				
<b>36620-93JD0</b>	6.5' / 2.0m Extension Harness				
<b>36620-93JE0</b>	9.8' / 3.0m Extension Harness				

\*Must use SMG4 for Auto-Trim feature

\*\*SMG4 Adapter cable 36661-96L30 not required when CAN main harness is used



# SUZUKI ANALOG INSTRUMENTS



## 4" Tachometers

7,000 max RPM Tachs are available with or without 4-Stroke monitor functions. Monitor functions include: Low Oil Pressure Warning, Engine Temperature Warning, Check Engine Warning and Over-Rev Limit Warning.

<b>34200-93J14</b>	White - With monitor functions
<b>34200-93J34</b>	White - Without monitor functions
<b>34200-93J02</b>	Black - With monitor functions
<b>34200-93J22</b>	Black - Without monitor functions

## Trolling Mode Control Switch

Allows the use of the Suzuki Trolling Mode on equipped engines. When Trolling Mode is engaged, this switch allows for adjustments of engine RPM in 50 RPM increments, from idle to 1,200 RPM to make setting and maintaining a trolling speed easy. Consult owner's manual or Suzuki Outboard Dealer for additional details on Suzuki Trolling System operation.



<b>37860-98L00</b>
DF40A/50A/50AV/60A/60AV/75A/90A/115A/115SS/140A/150A/150A/175A/200A

Suzuki Genuine Instruments are custom-designed to provide the quality, reliability and value you expect from Suzuki Products. The wide selection allows you to accurately monitor a variety of essential functions. All instruments are lighted for night-time boating and feature standard 2" and 4" diameters for easy installation.

## 4" Tachometer With Suzuki Trolling Mode Scale

Easy to read 4" Tachometer has a scale from 0-7,000 RPM for standard use and a secondary scale from 0-3,000 RPM with markers at 50 RPM intervals for use with the Suzuki Trolling Mode System. Gauge also includes warning lamps for Engine Temperature, Low Oil, Check Engine, and Over-Rev. When in Trolling Mode, Over-Rev Lamp stays on to indicate that Trolling Mode has been engaged. The secondary RPM scale is designed to make setting and maintaining a lower trolling speed simple. Fits DF40A/50A/50AV/60A/60AV/75A/90A/115A/140A (DF300/350A requires C-10 gauges) \*See engine owner's manual for information about Suzuki Trolling Mode System. Not all models come equipped with trolling mode system. Accessory Trolling Mode Switch is required for Suzuki Trolling Mode System use. Suzuki recommends the use of this gauge for trolling use.

<b>34200-93J54</b>	White - DF40A/50A/50AV/60A/60AV/75A/90A/115SS/115BG/140BG/140A/150SS/150A/175A/200A/200SS (DF150AP/175AP/200AP/250AP/300/300B/350A requires digital instrumentation)
<b>34200-93J43</b>	Black - DF40A/50A/50AV/60A/60AV/75A/90A/115SS/115BG/140BG/140A/150SS/150A/175A/200A/200SS (DF150AP/175AP/200AP/250AP/300/300B/350A requires digital instrumentation)



## 4" Speedometers

Bourdon-tube type speedometer with readings in M.P.H. and Km/h. Includes vinyl tube, plus all installation instructions and hardware. \*Pitot tube 34190-87D00 must be ordered separately.

<b>34100-93J13</b>	White - 80 mph
<b>34100-93J33</b>	White - 50 mph
<b>34100-93J02</b>	Black - 80 mph
<b>34100-93J22</b>	Black - 50 mph
<b>34190-87D00*</b>	Pitot Tube

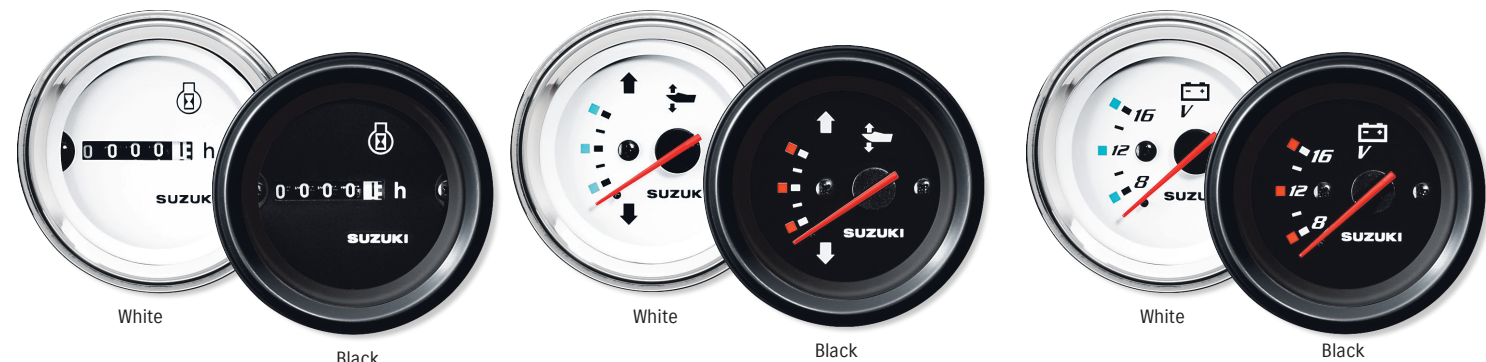

## 2" Hour Meter

12 volt electric motor driven meter indicates the number of hours your outboard motor has been operated to indicate when periodic services are necessary.

<b>34500-93J13</b>	White
<b>34500-93J02</b>	Black

## 2" Trim Gauge

Magnetic type gauge shows trim angle for optimum performance and efficiency.

<b>34800-93J13</b>	White
<b>34800-93J02</b>	Black

## 2" Voltmeter

A well charged battery is essential for quick and easy starts. Monitor the charging system using a Voltmeter.

<b>34600-93J13</b>	White
<b>34600-93J02</b>	Black



## 2" Fuel Gauge

Operates on 12 volts with magnetically damped needle. Works with most fuel tank sending units.

<b>34300-93J14</b>	White
<b>34300-93J02</b>	Black



## 2" Water Pressure Gauge 15 psi

Bourdon-tube type gauge measures cooling water pressure. Instructions and dash installation hardware included. Order Installation Kit for appropriate model.

<b>34650-93J33</b>	White
<b>34650-93J22</b>	Black

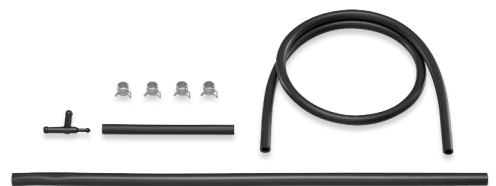

## Water Pressure Gauge Installation Kits

Kit includes fittings and hoses needed for motor to gauge connection.

<b>34660-93J02</b>	DF225/250/250AP/300AP
<b>34660-96J01</b>	DF150/150AP/150A/DF175/175AP/175A/200A
<b>34660-99E01</b>	DF60/70
<b>34660-87J01</b>	DF40/50
<b>34660-90J04</b>	DF40A/50A/50AV/60A/60AV/75A/90/DF90A/115/115A/140/140A

# SUZUKI ANALOG INSTRUMENTS

Economically priced, high-quality instruments feature easy plug-in wiring connections, perimeter-lighted dial, chrome bezels, contoured pointers and fog-resistant glass lenses. All use standard 2" or 4" diameters for easy dash installation.

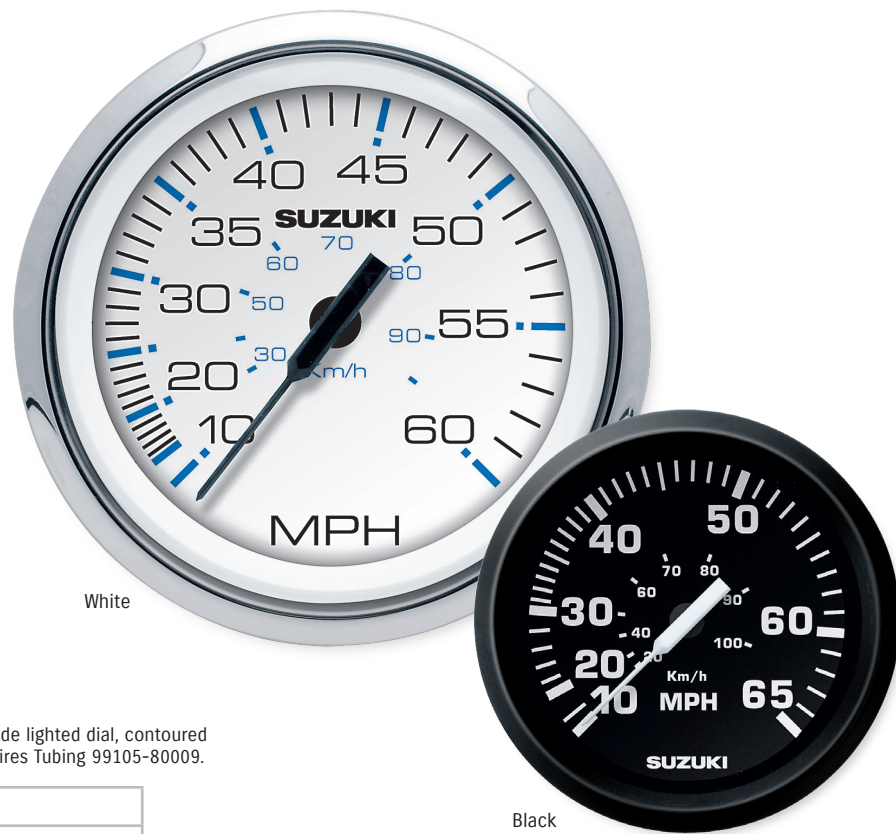

## 4" Speedometer

Easy to read 4" Speedometer features include lighted dial, contoured pointer and fog-resistant glass lens. \*Requires Tubing 99105-80009.

990C0-80102	White 60 mph
990C0-80009*	Speedometer Tubing (not shown)
990C0-80002	Black 65 mph
990C0-80009*	Speedometer Tubing (not shown)

## 4" Tachometers

7,000 max R.P.M. Tachs are available with or without 4-Stroke monitor functions. Monitor functions include: Low Oil Pressure Warning, Engine Temperature Warning, Check Engine Warning and Over-Rev Limit Warning.

990C0-80101	White - With monitor functions
990C0-80100	White - Without monitor functions
990C0-80001	Black - With monitor functions
990C0-80000	Black - Without monitor functions

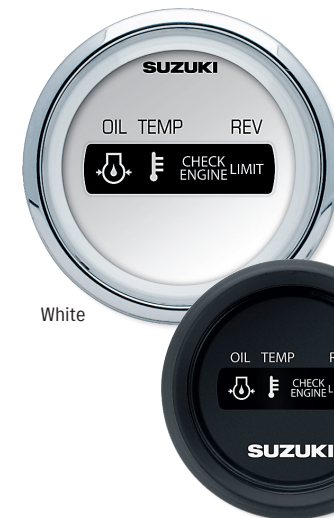
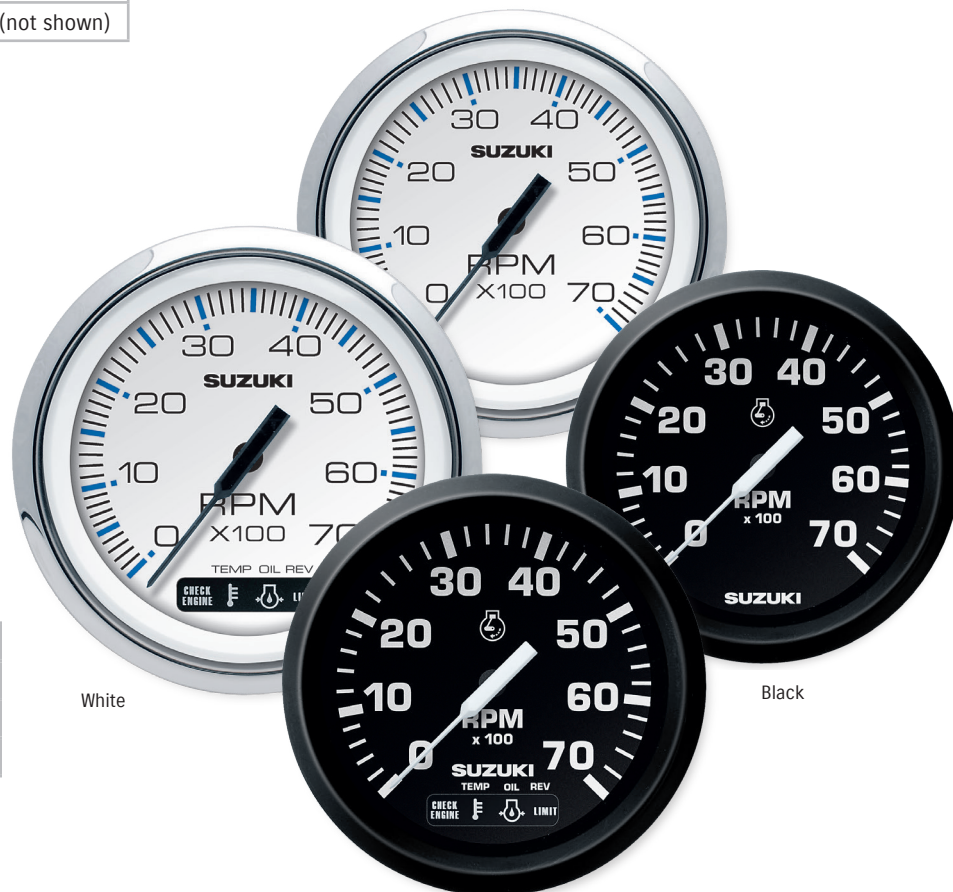

## 2" Engine Monitor Gauge

Engine Monitor Gauge for 4-stroke engines helps alert you to low oil pressure, high engine temperature and engine over-rev

990C0-80108	White
990C0-80008	Black



## 2" Trim Gauge

To help maintain steering stability and good performance, proper trim angle is essential. The Trim Gauge helps you monitor the trim angle. For use with 2-wire senders.

990C0-80105	White
990C0-80005	Black



## 2" Digital Hour Meter

Handy Hour Meter helps you keep track of the time between services and total running time.

990C0-80110	White
990C0-80010	Black



## 2" Fuel Gauge

Adding a Fuel Gauge can help you monitor fuel level. Connects easily using your boat's fuel sending unit harness.

990C0-80103	White
990C0-80003	Black



## 2" Voltmeter

A well charged battery is essential for quick and easy starts. Monitor the charging system by using a Voltmeter.

990C0-80106	White
990C0-80006	Black

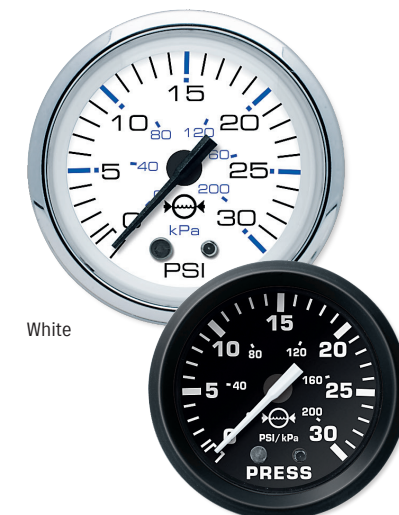

## 2" Water Pressure Gauge 30 psi

Bourdon-tube type gauge measures cooling water pressure. Instructions and dash installation hardware included. Order Installation Kit for appropriate model.

990C0-80104	White
990C0-80004	Black

## Water Pressure Gauge Installation Kits

Kit includes fittings and hoses needed for motor to gauge connection.

34660-93J02	DF225/250/250AP/300AP
34660-87J01	DF40/50
34660-96J01	DF150/150AP/150A/DF175/175AP/175A/200AP
34660-99E01	DF60/70
34660-90J04	DF40A/50A/50AV/60A/60AV/75A/90A/90/115/115A/140/140A







## Dual Engine Ignition and Emergency Stop Switch Panel Assembly

Dual Engine Ignition and Emergency Stop Switch Panel Assembly. Includes wiring, hardware and stop switch lanyard.

**37100-98L30** DF9.9B - DF250



## Emergency Stop Switch Panel Assembly

Emergency Stop Switch Panel Assembly. Includes wiring, hardware and lanyard.

**37803-98L00** DF9.9B - DF250



## Single Engine Ignition Switch Panel Assembly

Single Engine Ignition Switch Panel Assembly. Includes wiring and hardware.

**37100-98L00** DF9.9B - DF250



## Vertical Ignition Switch

**37100-98L10** DF9.9B - DF250



## Horizontal Ignition Switch

**37100-98L20** DF9.9B - DF250

## Single Engine Ignition and Emergency Stop Switch Panel Assembly

Single Engine Ignition and Emergency Stop Switch Panel Assembly. Includes wiring, hardware and stop switch lanyard.

## Switch Panel Assemblies

Genuine Suzuki Switch Panel Assemblies are designed to match and connect with other Suzuki components for easy installation and trouble-free operation.



## Trolling Mode Control Switch

Allows the use of the Suzuki Troll Mode on equipped engines. When Troll Mode is engaged, this switch allows for adjustments of engine RPM in 50 RPM increments, from idle to 1200 RPM to make setting and maintaining a trolling speed easy. Consult owner's manual or Suzuki Outboard Dealer for additional details on Suzuki Troll System operation.

**37860-98L00**

DF40A/50A/50AV/60A/60AV/75A/90A/115A/115SS/140A/150A/150A/175A/200A/150AP-300AP/300B-350A



## P.T.T. Switch Panel Assembly

P.T.T. Switch Panel Assembly. Includes wiring and hardware.

**37805-88L00** DF40A - DF250

## Aux Power Trim Switch (not shown)

Allows quick connection of remote trim switch with easy plug-in bullet connectors.

**36647-93J00**



## Thru-Hull Fitting And Hose Kits

Thru-Hull Fitting and Hose Kit can handle single, dual and triple motor installations. One Thru Hull Kit and one Adaptor Kit is necessary for each outboard used.

**990C0-20010**  
Includes:

- Black Thru Hull Kit
- 1 - 4' Black Hose
- 1 - Fuel Hose Port
- 1 - 2" Thru-Hull Fitting
- 2 - Stainless Steel Bolts & Nuts

**990C0-20020**  
Includes:

- White Thru Hull Kit
- 1 - 4' White Hose
- 1 - Fuel Hose Port
- 1 - 2" Thru-Hull Fitting
- 2 - Stainless Steel Bolts & Nuts

## Suzuki Performance Remote Control Cables

Suzuki Performance Cables have a unique design that incorporates a patent-pending splined core. Ridges on the core allow a close fit to the cable's inner liner with minimum contact, allowing the core to glide back and forth smoothly. All cables are factory tested and approved for heavy use applications. Order cable length as needed.

Black HDPE super tough casing

Oil tempered reinforced lay wire for high strength and flexibility

Heavy-duty HDPE inner liner for minimal drag and long life

Splined core for high efficiency and minimal backflash

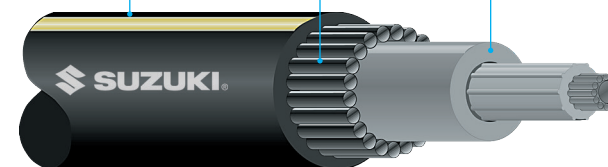

<b>990C0-11002-008</b>	8'	<b>990C0-11002-014</b>	14'	<b>990C0-11002-020</b>	20'	<b>990C0-11002-026</b>	26'
<b>990C0-11002-009</b>	9'	<b>990C0-11002-015</b>	15'	<b>990C0-11002-021</b>	21'	<b>990C0-11002-027</b>	27'
<b>990C0-11002-010</b>	10'	<b>990C0-11002-016</b>	16'	<b>990C0-11002-022</b>	22'	<b>990C0-11002-028</b>	28'
<b>990C0-11002-011</b>	11'	<b>990C0-11002-017</b>	17'	<b>990C0-11002-023</b>	23'	<b>990C0-11002-029</b>	29'
<b>990C0-11002-012</b>	12'	<b>990C0-11002-018</b>	18'	<b>990C0-11002-024</b>	24'	<b>990C0-11002-030</b>	30'
<b>990C0-11002-013</b>	13'	<b>990C0-11002-019</b>	19'	<b>990C0-11002-025</b>	25'		



## Main Wiring Harnesses

Analog / K-Line Main Wiring Harnesses. Order length as needed for rigging applications.

<b>36620-89L10</b>	DF9.9B/15A/20A	21'
<b>36620-94L20</b>	DF25A/DF30A	21'
<b>36620-93J80</b>	DF40A-DF250	16'
<b>36620-93J70</b>	DF40A-DF250	21'
<b>36620-93J90</b>	DF40A-DF250	26'
<b>36620-93J12</b>	DF9.9B-DF250	6.5' Extension
<b>36620-93J42</b>	DF9.9B-DF250	10' Extension



## Battery Isolator Lead Set

Used for charging auxiliary battery.

<b>33830-96J00</b>	DF150/175 (S/N Models up to 499999)
<b>33830-98J11</b>	DF150/175 (S/N Models 510001 and newer) DF200AP/175AP/150AP/250A/300AP/300B
<b>33830-98J02</b>	DF300 (S/N Models up to 199999)

## Adapter Kits

Kit Includes:

- 1 - Through-Hull attachment
- 2 - pins,
- 2 - e-rings



<b>67300-98J10</b>	DF115A/140A/150/175/200A/200AP/DF250AP/300AP/300B/350A 2016-Newer
<b>67300-93J01</b>	DF150/175/200/225/250/300 2006-2015
<b>67300-90J00</b>	DF75A/90A/115/140 2006-2015

## Replacement Lanyard

Replacement Lanyard for Emergency Stop Switch.

**37823-92E02**



## Replacement Ignition Keys (not shown)

<b>37141-99E00</b>	Key 931	<b>37141-99E60</b>	Key 937
<b>37141-99E10</b>	Key 932	<b>37141-99E70</b>	Key 938
<b>37141-99E20</b>	Key 933	<b>37141-99E80</b>	Key 939
<b>37141-99E30</b>	Key 934	<b>37141-99E90</b>	Key 940
<b>37141-99E40</b>	Key 935	<b>37141-99EA0</b>	key 941
<b>37141-99E50</b>	Key 936	<b>37141-99EB0</b>	Key 942

# STEERING



## Tiller Handle Kits

New fully-integrated tiller handle with digital tachometer display. Includes redesigned, more ergonomic shift lever.

PEARL NEBULAR BLACK	
63002-88L2A-YAY	DF40A/50A
63002-88L18-YAY	DF50AV/60A/60AV
63002-87L18-YAY	DF70A/90A 2021- Prior
63002-87L20-YAY	DF75A/90A (*22 - Current)
63002-90J38-YAY	DF115A
63002-99L00-YAY	DF115B

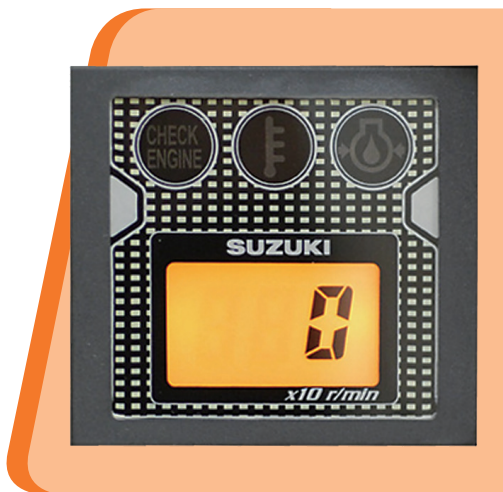

Digital Tachometer



Shift Lever



Angle Adjustable Bracket



## Tiller Handle Kits

Tiller Handle Kits are designed for easy installation for selected electric start models. Kit includes ignition switch, engine stop switches, wiring harness, cables and grommets.

63002-87J42-0EP	DF40/50	2005 - 2009
63002-88L33-0EP	DF40A/50A/60A	2010 - 2015
63002-87L09-0EP	DF75A/90A	2009 - 2015
63002-90J43-0EP	DF90/115 w/ Hydraulic Tensioner	2005 - 2015



## Dual Cable Steering Kit

Kit allows you to attach two steering cables for added reliability.

990C0-10004	DF150 - DF250
-------------	---------------



## Twin Engine Adapter Plate Set

Adapter plates are used when installing a tie bar on a D115A/140A.

99105-10005	DF115A/140A
	*Does NOT fit DF90A



## Drag Link Kits

Corrosion-resistant stainless steel Drag Links are specially designed for use with Suzuki Outboard Motors.

67701-99J02	DF9.9B-DF20A	'10 - Current
67701-93E12	DF9.9/15	'97 - '10
67701-94L00	DF25A/30A	
67701-87J11	DF40/50	'99 - '10
	DF40A-60A/200-250	'10 - Current
	DF60/70	'98 - '10
67701-87L01	DF75A/90A	'09 - Current
67701-90J01	DF90/115/140A	'01 - Current
67701-96J00	DF150-175/200A/AP	'06 - Current
67700-93J00	DF225/250	'04 - Current



## Dual Engine Tie Bar

Stainless steel Tie Bar for dual engine steering, adjustable up to 36".

990C0-10006	DF40A - DF140A
67600-93J00	DF150/175/200AP
67600-99L00	DF115BG/140BG



## Compact Water Separator/Fuel Filter

Compact size Water Separator/Fuel Filter is ideal for smaller boat-motor combinations of up to 140 H.P. Not for 150 and above.

99105-20006	Replacement Filter
99105-20006-ASY	Complete Assembly
99105-20006-BWL	Bowl and Drain Valve Assembly



## Water Separator/Fuel Filter

State-of-the-art filter removes water and other contaminants from the fuel before they reach your engine. It features a transparent removable bowl for easy viewing of fuel condition and a drain valve for water and other impurities. Due to the high flow rate capabilities of this filter system, a special large diameter thread is used. Use only Genuine Suzuki Replacement Filter 99105-20005. Applicable to all models, recommended 150 and up.

99105-20005	Replacement Filter
99105-20005-ASY	Complete Assembly
99105-20004-BWL	Bowl and Drain Valve Assembly



## Bowl Wrench

99105-20003	Bowl Wrench
-------------	-------------



## Plastic Fuel Tanks\*

Constructed of tough, lightweight, high-density polyethylene and made to CARB / EPA standards.

65000-99J01	3 Gallon Tank without Fuel Level Gauge, 11mm connector
65000-95J01	6.6 Gallon Tank with Fuel Level Gauge, 13mm connector

\* Not for use with DF 4/6 without fuel hose with pressure regulator. See dealer for details.

## FUEL CONNECTORS - MOTOR SIDE

Male connectors are located on the motor side, for fuel hose attachment.

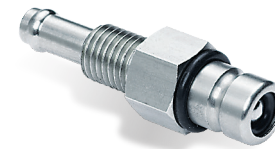

65720-985L1	OD:11mm Plated Brass	DT3.5 - 65
-------------	-------------------------	------------



65720-955L1	OD:13mm Plated Brass	DT75 - 140A
-------------	-------------------------	-------------



65720-94403	OD:13mm Plastic	DT4 - 65
-------------	--------------------	----------

## FUEL TANK CONNECTORS

Fuel tank connectors are available in stainless steel with metric thread and plated brass with 1/4" NPT.

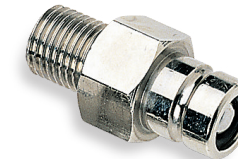

65740-95501	OD:13mm Metric	All Models
-------------	----------------	------------



99105-00192	OD:11mm 1/4" NPT	U.S. Tanks
-------------	------------------	------------



99105-00193	OD:13mm 1/4" NPT	U.S. Tanks
-------------	------------------	------------

## FUEL HOSE CONNECTORS

Quick connect and disconnect female fittings fit either hose end.



65750-98506	ID:11mm	Metal for small diameter hoses
-------------	---------	--------------------------------



65750-95501	ID:13mm	Metal for small diameter hoses
-------------	---------	--------------------------------



65750-87J11	Plastic	DF4 - 140A
-------------	---------	------------

## Internal Engine Fuel Filters

Engine Model	Year	Part Number
DF4/6	2002-2016	15410-98500
DF4A/6A	2017-Current	44330-13H00
DF9.9A	2010-Current	44330-13H00
DF9.9/15	2011-2013	15410-98500
DF9.9B/15A/20A	2013-Current	15410-87L00
DF25 V-Twin	2006-2010	15410-87J30
DF25/30	2001-2010	15410-87J10
DF25A/30A	2015-Current	15410-87L00
DF40/50	Late 2006-2010	15410-87J30
DF40A/50A/60A	2010-Current	15410-88L00
DF50AV/60AV	2014-Current	15410-88L00
DF60/70	2007-2009	15410-87J30
DF70A/75A/80A/90A	2009-Current	15410-87L00
DF115/140	2010-2012	15410-87J30
DF115B/140B Including G models	2020-Current	15410-87J30
DF115A/140A/115SS	2013-Current	15412-92J00
DF150/175/150SS	2006-Current	15410-96J00
DF150A/175A/200A	2016-Current	15412-92J00
DF200/225/250 V6	2011-Current	15412-93J10
DF250A/300A/300AP/250SS	2011-Current	15412-93J10
DF300B/300BMD/350A/350AMD	2017-Current	15412-93J10



65750-94404	ID:13mm Plastic	DT4 - 140A
-------------	-----------------	------------



65720-986L0	Plastic	DF4 - 140A
-------------	---------	------------

# PROPELLERS

## DF4/6 (Optional '03-'10)

Material	Blades	Diameter	Pitch	Part Number	DF4	DF6
Aluminum	3	7-1/2	6	58110-91JL0-019	'04-Current	'04-Current
Aluminum	3	7-1/2	6-1/2	58110-91JM0-019	'04-Current	'04-Current
Aluminum	3	7-1/2	7	58110-91JN0-019	'04-Current	'04-Current
Aluminum	3	7-1/2	6	58111-98602-019	'03	
Aluminum	3	7-1/2	6-1/2	58111-98641-019	'03	
Aluminum	3	7-1/2	7	58111-98651-019	'03	

Diameter and pitch are measured in inches. ■=Optional. Refer to the Bushing Application Chart.

## DF9.9/15/20

Material	Blades	Diameter	Pitch	Part Number	DF9.9	DF15/20
Aluminum	3	9-1/4	7	58100-89L00-019	■	■
Aluminum	3	9-1/4	8	58100-90L41-019	■	■
Aluminum	3	9-1/4	9	58100-90L50-019	■	■
Aluminum	3	9-1/4	10	58100-90L60-019	■	■
Aluminum	3	9-1/4	11	58100-89L70-019	■	■
Aluminum	3	9-1/4	12	58100-89L50-019	■	■
Aluminum	3	9-1/4	10	58100-90L60-019	■	■
Aluminum	4	10	5	58100-94JA2-019	■	

Diameter and pitch are measured in inches. ■=Optional.

## DF9.9B/15A/20A

Material	Blades	Diameter	Pitch	Part Number	DF15A/20A
Aluminum	3	9-1/4	8	58100-90L41-019	■
Aluminum	3	9-1/4	9	58100-90L50-019	■
Aluminum	3	9-1/4	10	58100-90L60-019	■
Aluminum	3	9-1/4	11	58100-89L70-019	■
Aluminum	3	9-1/4	12	58100-89L50-019	■

Diameter and pitch are measured in inches. ■=Optional.

## Propeller Bushing Application

Applications	Bushing Type	Bushing	Stopper	Spacer	Washer	Nut
DF4 '03 Models	Push-In	58120-98600				58130-91JL0
DF4 '04 - Current Models	Press-In	58120-91JL0	57635-91JL0	58130-91JL0	58100-90L41-019	58100-90L41-019
DF6 '03 - Current Models	Press-In	58120-91JL0	57635-91JL0			58130-91JL0
DF9.9/9.9A/9.9B/15/15A/20A	Press-In	58120-89L00	57632-94J00	57633-93901	09160-12066	09141-12005
DF25/30 '00 - Current Models	Press-In	58120-96401	57632-96400	57633-96300	09160-14028	09141-14008
DF25 V-Twin	Press-In	58120-96401	57632-95J00	57633-96300	09160-14028	09141-14008
DF40/50	Press-In	58120-88L01	57632-95320	57633-94301	09160-18028	09141-18005
DF40A/50A/60A '10 - Current Models	Press-In	58120-88L01	57632-95320	57633-94301	09160-18028	09141-18005
DF60/70	Press-In	58120-95500	57635-95510	57633-95501	09160-18028	09141-18005
DF60/70	Press-In	58120-94520	57635-94511	57633-94500	09160-18028	09141-18005
DF75A/90A '09 - Current Models	Press-In	58120-90J00	57632-87L01	57633-90J02	09160-18028	09141-18005
DF90/115/140A	Press-In	58120-90J00	57635-90J01*		09160-18028	09141-18005
DF90/115/140A	Press-In	58120-90J00	57635-90J01*	year specific	09160-18028	09141-18005
DF90/115/140A '01 - '02 Models	Press-In	58120-90J00	57635-90J01*	year specific	09160-18028	09141-18005
DF90/115/140A '03 - '08 Models	Press-In	58120-90J00	57635-90J01*	year specific	09160-18028	09141-18005
DF115/140A Counter Rotation Models	Press-In	58120-90J00	57635-92J01*	year specific	09160-18028	09141-18005
DF150/175/200/200A/225/250/250AP/300/300AP	Press-In	58105-93J00	57632-93J11	57633-87D30	09160-18028	09141-18005
DF250SS	Press-In	58105-93J10	57632-93J21	57633-87D30	09160-18028	09141-18005

\*Uses Spacer For Stopper, 57632-90J00

## Watergrip Bushing Application

Engine Model	Stopper	Propeller Bushing	Kit	INCLUDED IN KIT				
				Spacer	Washer	Stopper	Nut	Cotter Pin
DF2.5	-	-	-	-	-	-	58130-91JL0	09204-03003
DF4A/6A	57635-97L00	58120-91JL0	N/A	-	-	-	58130-91JL0	09204-03003
DF8A/9.9A	57632-94J00	58120-89L00	57630-99J00	-	09160-12066	-	09141-12005	09204-02004
DF9.9/9.9B/15A/15C/20A	57632-94J00	58120-89L00	57630-93901	-	09160-12066	-	09141-12005	09204-02004
DF25A/30A	57632-91L00	58120-96401	57630-96300	57633-96300	09160-14028	-	09141-14008	09204-03003
DF40A/50A/60A	57632-95320	58120-88L01	57630-94301	57633-94301	09160-18028	-	09141-18005	09204-03003
DF50A/60AV	57635-90J01	58105-90J00	57630-90J10	57633-90J02	09160-18028	-	09141-18005	09204-03003
DF75A/90A	57632-87L01	58105-90J00	57630-90J10	57633-90J02	09160-18028	-	09141-18005	09204-03003
DF115A/115BG/140A/140BG	57635-92J01	58105-90J00	57630-90J10	57633-90J02	09160-18028	-	09141-18005	09204-03003
DF150-DF300 Non-Watergrip	57632-93L01	-	57630-92E00	57633-87D30	09160-18019	-	09141-18005	09204-03003
DF150A-DF300AP Watergrip	57632-93L11	58120-93L00	57630-93L00	57633-93L00	09160-18028	-	09141-18005	09204-03003
DF300B/350A Front	58531-98L00	58520-98L00	58540-98L10	58541-98L00	-	58551-98L00	58561-98L01	-
DF300B/350A Rear	58631-98L00	58520-98L00	58640-98L10	58641-98L00	09160-18019	-	09141-18005	09204-03003



## Propeller Hardware Kits

Includes the spacer, cotter key, washer and nut to secure the propeller to the shaft.

57630-99J00	DF8A/9.9A
57630-93900	DF9.9B/15A/20A
57630-96300	DF25A/30A
57630-94301	DF40A/50A/60A
57630-90J00	DF50AV/60AV
	DF75/90A
	DF115A/115B/115BG
	DF140A/140B/140BG
57630-93L00	DF150A-DF300AP (Watergrip)
57630-92E00	DF150-DF300AP (Non-Watergrip)
58540-98L00	DF300B/DF350A Front
58640-98L00	DF300B/DF350A Rear

## DF25A/30A

Material	Blades	Diameter	Pitch	Part Number	DF25A/30A
Aluminum	3	10-1/4	9	58100-96372-019	■
Aluminum	3	10-1/4	10	58100-91L40-019	■
Aluminum	3	10-1/4	10	58100-96472-019*	■
Aluminum	3	10-1/4	11	58100-91L50-019	■
Aluminum	3	10-1/4	12	58100-96482-019	■
Aluminum	3	10-1/4	13	58100-96492-019	■
Aluminum	3	10-1/4	14	58100-95D01-019	■
Aluminum	3	10-1/4	15	58100-96462-019	■

Diameter and pitch are measured in inches. ■=Optional.

\*Thicker Blade

## DF60/70

Material	Blades	Diameter	Pitch	Part Number	'98 - '09
Aluminum	3	14	11	58100-99E10-019	■
Aluminum	3	13-3/4	13	58100-99E00-019	■
Aluminum	3	13-1/2	15	58100-94500-019	■
Aluminum	3	13-1/4	17	58100-94512-019	■
Aluminum	3	13	19	58100-94522-019	■
Aluminum	3	13	21	58100-94532-019	■

Diameter and pitch are measured in inches. Extremely durable stainless steel propellers especially designed for high performance boats. ■=Optional. Type V Cupped aluminum propeller with press-in bushing.

## DF40A/50A/60A

Material	Blades	Diameter	Pitch	Part Number	'99 - Current
Aluminum	3	11-1/2	9	58100-88LC0-019	■
Aluminum	3	11-1/2	10	58100-88LD0-019	■
Aluminum	3	11-1/2	11	58100-88LE0-019	■
Aluminum	3	11-5/8	12	58100-88LA0-019	■
Aluminum	3	11-1/2	13	58100-88LB0-019	■
Aluminum	3	11-3/8	14	58100-88L52-019	■
Aluminum	3	11-1/4	15	58100-88L62-019	■
Aluminum	3	11-1/8	16	58100-88L72-019	■
Aluminum	3	11	17	58100-88LF0-019	■
Stainless Steel	3	11-3/4	10	990C0-00600-10P	■
Stainless Steel	3	11-3/4	11	990C0-00600-11P	■
Stainless Steel	3	11-3/4	12	990C0-00600-12P	■
Stainless Steel	3	11-3/4	13	990C0-00600-13P	■
Stainless Steel	3	11-3/4	14	990C0-00600-14P	■
Stainless Steel	3	11-3/4	15	990C0-00600-15P	■
Stainless Steel	3	11-3/4	16	990C0-00600-16P	■
Stainless Steel	3	11-3/4	17	990C0-00600-17P	■

Diameter and pitch are measured in inches. ■=Optional.

## DF50AV/60AV/75A/90A/115/115A/115BG/140/140A/140BG

Material	Blades	Diameter	Pitch	Part Number	'99 - Current
Aluminum	3	14	9	990C0-00750-09P	■
Aluminum	3	14	11	990C0-00750-11P	■
Aluminum	3	14	13	990C0-00750-13P	■
Aluminum	3	13-7/8	15	990C0-00750-15P	■
Aluminum	3	13-3/4	17	990C0-00750-17P	■
Aluminum	3	13-3/4	19	990C0-00750-19P	■
Aluminum	3	13-3/4	21	990C0-00750-21P	■
Aluminum	3	13-3/4	23	58100-87LF0-019	■
Aluminum	3	13-1/2	15	990C0-00760-15P	■
Aluminum	3	14	17	990C0-00760-17P	■
Aluminum	3	14	19	990C0-00760-19P	■
Aluminum	3	14	21	990C0-00760-21P	■
Aluminum	3	14	23	990C0-00760-23P	■
Stainless Steel	3	14	15	990C0-00610-15P	■
Stainless Steel	3	14	16	990C0-00610-16P	■
Stainless Steel	3	14	17	990C0-00610-17P	■
Stainless Steel	3	14	18	990C0-00610-18P	■
Stainless Steel	3	14	19	990C0-00610-19P	■
Stainless Steel	3	14	20	990C0-00610-20P	■
Stainless Steel	3	14	21	990C0-00610-21P	■
Stainless Steel	3	14	22	990C0-00610-22P	■
Stainless Steel	3	14	23	990C0-00610-23P	■
Stainless Steel	3	14	24	990C0-00610-24P	■
Stainless Steel	3	14	25	990C0-00610-25P	■
Stainless Steel	3	14	26	990C0-00610-26P	■

Diameter and pitch are measured in inches. ■=Optional.

## Counter Rotation 610 Series Propellers for DF50AV/60AV/75A/90A/115/115A/140/140A

Material	Blades	Diameter	Pitch	Part Number	'09 - Current
Stainless Steel	3	14	15	990C0-00611-15P	■
Stainless Steel	3	14	16	990C0-00611-16P	■
Stainless Steel	3	14	17	990C0-00611-17P	■
Stainless Steel	3	14	18	990C0-00611-18P	■
Stainless Steel	3	14	19	990C0-00611-19P	■
Stainless Steel	3	14	20	990C0-00611-20P	■

# DF300B/350A PROPELLERS AND TOOLS

## DF300B/DF350A Propellers

Material	Blades	Diameter	Pitch	Part Number		
Stainless Steel	3	15-1/2"	12	<a href="#">990C0-0091R-12P</a>	Rear Propeller	■
Stainless Steel	3	15-1/2"	15	<a href="#">990C0-0091R-15P</a>	Rear Propeller	■
Stainless Steel	3	15-1/2"	16.5	<a href="#">990C0-0091R-165</a>	Rear Propeller	■
Stainless Steel	3	15-1/2"	18	<a href="#">990C0-0091R-18P</a>	Rear Propeller	■
Stainless Steel	3	15-1/2"	19.5	<a href="#">990C0-0091R-195</a>	Rear Propeller	■
Stainless Steel	3	15-1/2"	21.0	<a href="#">990C0-0091R-21P</a>	Rear Propeller	■
Stainless Steel	3	15-1/2"	22.5	<a href="#">990C0-0091R-225</a>	Rear Propeller	■
Stainless Steel	3	15-1/2"	24.0	<a href="#">990C0-0091R-24P</a>	Rear Propeller	■
Stainless Steel	3	15-1/2"	25.5	<a href="#">990C0-0091R-255</a>	Rear Propeller	■
Stainless Steel	3	15-1/2"	27.0	<a href="#">990C0-0091R-27P</a>	Rear Propeller	■
Stainless Steel	3	15-1/2"	28.5	<a href="#">990C0-0091R-285</a>	Rear Propeller	■
Stainless Steel	3	15-1/2"	30.0	<a href="#">990C0-0091R-30P</a>	Rear Propeller	■
Stainless Steel	3	15-1/2"	31.5	<a href="#">990C0-0091R-315</a>	Rear Propeller	■
Stainless Steel	3	15-1/2"	12	<a href="#">990C0-0090F-12P</a>	Front Propeller	■
Stainless Steel	3	15-1/2"	15	<a href="#">990C0-0090F-15P</a>	Front Propeller	■
Stainless Steel	3	15-1/2"	16.5	<a href="#">990C0-0090F-165</a>	Front Propeller	■
Stainless Steel	3	15-1/2"	18	<a href="#">990C0-0090F-18P</a>	Front Propeller	■
Stainless Steel	3	15-1/2"	19.5	<a href="#">990C0-0090F-195</a>	Front Propeller	■
Stainless Steel	3	15-1/2"	21.0	<a href="#">990C0-0090F-21P</a>	Front Propeller	■
Stainless Steel	3	15-1/2"	22.5	<a href="#">990C0-0090F-225</a>	Front Propeller	■
Stainless Steel	3	15-1/2"	24.0	<a href="#">990C0-0090F-24P</a>	Front Propeller	■
Stainless Steel	3	15-1/2"	25.5	<a href="#">990C0-0090F-255</a>	Front Propeller	■
Stainless Steel	3	15-1/2"	27.0	<a href="#">990C0-0090F-27P</a>	Front Propeller	■
Stainless Steel	3	15-1/2"	28.5	<a href="#">990C0-0090F-285</a>	Front Propeller	■
Stainless Steel	3	15-1/2"	30.0	<a href="#">990C0-0090F-30P</a>	Front Propeller	■
Stainless Steel	3	15-1/2"	31.5	<a href="#">990C0-0090F-315</a>	Front Propeller	■

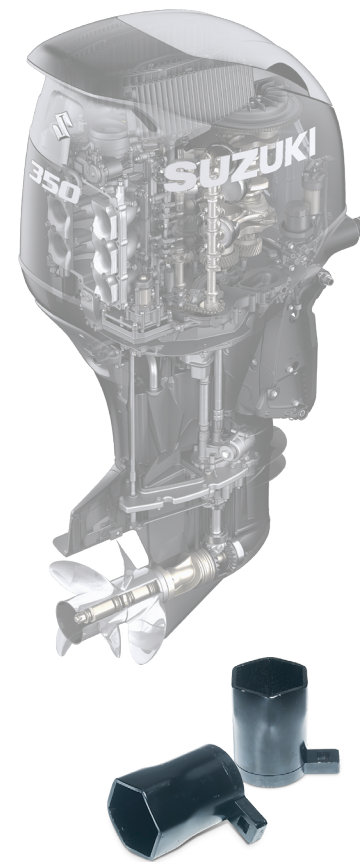

## DF300B/DF350A Accessories

<a href="#">99924-29810-LPT</a>	Prop Tool
<a href="#">99000-81202</a>	Flush Kit (2017 - 2022)
<a href="#">99000-81210</a>	Flush Kit (2023 - Forward)
<a href="#">17917-87L00</a>	Flushing Attachment

## Propeller Hardware Kits

Includes the spacer, cotter key, washer and nut to secure the propeller to the shaft.

<a href="#">58540-98L00</a>	DF300B/DF350A Front
<a href="#">58640-98L00</a>	DF300B/DF350A Rear

## Development of Suzuki's First Contra-Rotating Propeller

After years of outboard design, Suzuki engineers knew that the shape of the lower unit and the design of the propeller would have a critical impact on performance. The increased power of the new engine required more powerful gears, and more powerful gears were typically larger. After considering alternatives, an innovative idea was proposed: design a contra-rotating dual propeller system. The contra-rotating propeller would certainly provide more "grip" underwater, and because contra-rotating propellers distribute the engine torque evenly over the two propellers, the torque per propeller decreases and gear diameter can be reduced. A reduction in gear diameter could then lead to the design of a smaller, more hydrodynamic gear case.

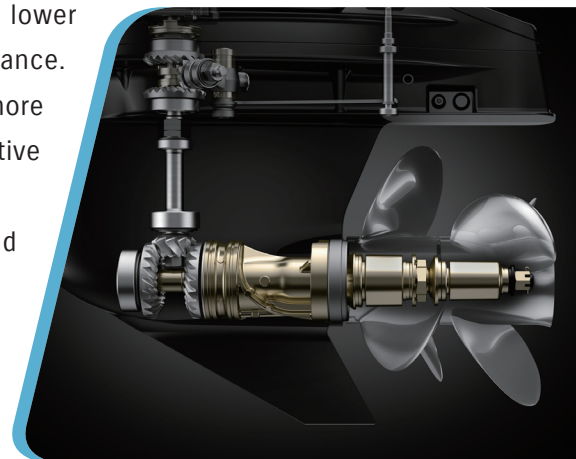

# REPAIR KITS & ANODES



## Gear Case Seal Kit

Part Number	Application	Years
25700-95D03	DT25C/30C/DF25/30 (except V-Twin)	
25700-95J00	DF25 V-Twin	All
25700-88L03	DT40C/DF40/50/40A/50A/60A	All
25700-99E00	DF60/70	2001 - 2010
25700-87L01	DF75A/90A	2009-Current
25700-90J01	DF90/115	2001-2011
25700-92J00	DF140/115A/140A/115B/140B	All
25700-93J00	DF150/175/200/200AP/225/250	All
25700-98J01	DF250SS/300	All
25700-93L02	DF250AP/300AP	All
25700-98L04	DF300B/350A	2017-2022
25700-87M10	DF300B/300BMD/350A/350AMD	2023-Current

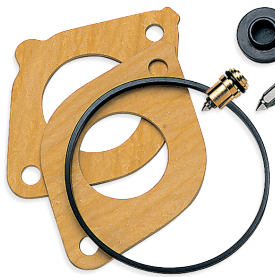

## Carburetor Repair Kit

Part Number	Application	Years
13910-89J01	DF25/30 (Except V-Twin)	All
13910-94400	DF40/65/85/140	All
13910-94701	DF55/75/115	All
13910-87D01	V6, 2-Stroke Models	All

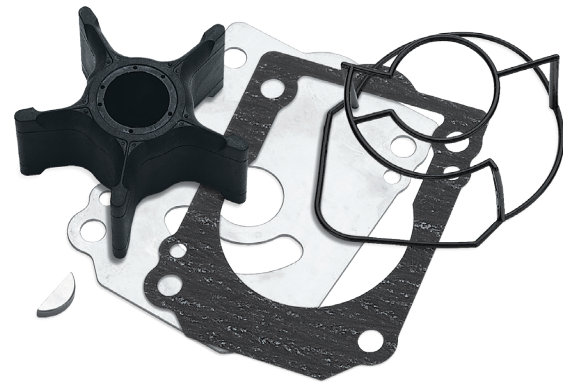

## Water Pump Repair Kit

### FOUR STROKE

Part Number	Application	Years
17400-986L2	DF4/6	2002 - 2010
	DF4/6	2011 - 2016
	DF4A/6A	2017 - Current
17400-93951	DF9.9/15	1997 - 2006
17400-94J00	DF9.9/15	2007 - 2013
17400-99J20	DF9.9A	ALL
	DF9.9B/15A/20A	2013 - Current
17400-95J03	DF25 V-Twin	2006 - 2010
17400-96354	DF25/30	ALL
17400-94L21	DF25A/30A	2015 - Current
17400-96354	DF40/50	1999 - 2010
17400-88L01	DF40A/50A/60A	2011 - Current
17400-99E12	DF50AVT/60AVT	ALL
17400-87E04	DF60/70	1998 - 2007
17400-99E01	DF60/70	2008 - 2009
17400-87L04	DF75A/80A/90A	2009 - Current
17400-90J20	DF90/115/140	2001 - 2005
17400-92J00	DF90/115/140	2006 - 2008
17400-92J23	DF115/115A/140/140A	2009 - Current
17400-96J04	DF200/225/250 (V6)	2006 - Current
17400-93J05	DF150A/175A/200A	2004 - Current
17400-98J05	DF200/225/250 (V6)	2008 - Current
	DF250SS	2007 - Current
17400-98L03	DF300B/350A	2017 - 2022
17400-87M00	DF300B/300BMD/350A/350AMD	2023 - Current

## ALUMINUM ANODES FOR BRACKISH AND/OR SALTWATER



55321-87J01	All Models	All Years
-------------	------------	-----------

## ZINC ANODES FOR SALTWATER USE ONLY

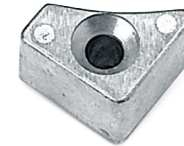

11281-94400	DF60/70	'98 - '01
-------------	---------	-----------



55321-90L00	DF9.9/15	'97 - '10
-------------	----------	-----------



55125-90J01	DF90-140	'98 - Current
-------------	----------	---------------

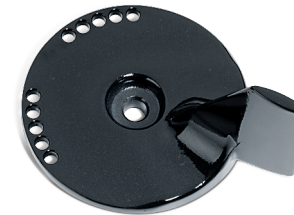

55125-98J00-OEP	DF200/225/250/300	Trim Tab
-----------------	-------------------	----------



55125-95500	DF40/50	'99 - '10
	DF40A/50A/60A	'10 - Current



55125-98J10	DF250SS	'08 - Current
-------------	---------	---------------



55125-93L00-OEP	DF250AP/300AP	'13 - Current
-----------------	---------------	---------------



55125-92J00	DF115/140	'08 - Current
-------------	-----------	---------------

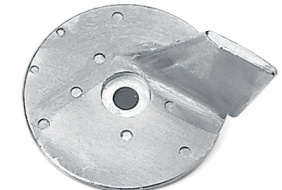

55125-96310	DF25/30	'00 - '10
	DF25 V-Twin	'06 - Current



55300-95500	DF9.9/15	'04 - '10
		'96 - '03
	DF40/50	'99 - '10
	DF40A/50A/60A	'10 - Current



55320-95311	DF25 /30	'00 - '07
	DF40/50	'99 - '08
	DF40A/50A/60A	'10 - Current
	DF60/70	'01 - '08
	DF150/175	'06 - Current
	DF200/225/250/300	'04 - Current



55320-94900	DF60 thru 300	'01 - '10
-------------	---------------	-----------



55321-90J01	DF60-140	'98 - '08
-------------	----------	-----------



55321-93J01*	DF300B/DF350A	All models
*Also requires P/N 09116-06236 (Bolt)		



55321-939L0	DF9.9/15	'97 - '08
-------------	----------	-----------

## ECSTAR® Marine 4-Cycle Engine Oil

Ecstar V7000 Semi-Synthetic Oil is specifically formulated for the Ultimate Outboard Motor. Premium mineral oils and synthetic lubricants, with an additive profile designed to stand up to harsh conditions on the water. FC-W Certified. See chart for recommended oil filter and capacities.

<b>990C0-01E30-QUA</b>	1 QT. Bottle	12/Case
<b>990C0-01E30-GLN</b>	1 GL Bottle	4/Case
<b>990C0-01E30-DRU</b>	55 Gallon Drum	

Dealers: Engine Oil must be ordered separately from all Parts and Accessories. See Suzuki Connect for instructions.



## Four-Stroke

Gear oil capacities are for reference only. Please consult your engine owners manual for gear oil change procedure and specifications.

Engine Model	Gear Case Oil Capacity (ml)	Gear Case Oil Capacity (oz)
DF4/6	190 ml.	6.4 oz.
DF9.9/15	175 ml.	5.9 oz.
DF9.9B/15A/20A	250 ml.	8.4 oz.
DF25/30	230 ml.	7.8 oz.
DF25A/30A	330 ml.	11.1 oz.
DF25V-Twin	420 ml.	14.2 oz.
DF40A/50A/60A/40/50	610 ml.	20.6 oz.
DF60/70	1050 ml.	35.5 oz.
DF75A/90A	850 ml.	28.7 oz.
DF90/115/140	1050ml.	35.5 oz.
DF115A/115B/140A/140B	1050 ml.	35.5 oz.
DF150/175/200/225/250/250S	1100 ml.	37.2 oz.
DF250AP/300/300AP	1100 ml.	37.2 oz.
DF300B/350A (2017 - 2022)	3218 ml.	108.8 oz.
DF300B/350A (2023 - Forward)	2895 ml.	101.9 oz.



## Gear Lube Pump

The Gear Lube Pump is developed to make changing the gear case oil in your lower units a whole lot easier. The pump is specially designed to fit and function with our Hypoid Gear Oil bottles and Suzuki outboard lower units. Includes 8mm and 10mm adapters.

**990C0-99002**



## Hypoid Gear Oil

Hypoid Gear Oil is formulated to Suzuki specifications. Available in two convenient sizes: 1 quart bottle and 5 gallon bucket. See chart for recommended gear oil capacities.

<b>990A0-01E81-01Q</b>	1 Quart	12/Case
<b>990A0-01E81-05G</b>	5 Gallon Pail	



## Fuel Conditioner & Water Remover

Removes water and helps clean fuel system. Helps to keep injectors and carburetors clean and corrosion free. Dissolves gum and varnish and helps prevent fuel line freezing. Use regularly for best result. 12oz bottle treats 3-12 gallons of gasoline.

**990A0-02E30-12Z** 12 Fluid oz. Bottle 12/Case



## Fuel Injector Cleaner

Quickly cleans deposits in gasoline injectors and helps to avoid costly injector replacement. Also helps prevent deposit build up with regular use and will not harm catalytic converters or oxygen sensors. Mix ratio 1:1, 12oz bottle treats 12 gallons of gasoline.

**990A0-02E25-12Z** 12 Fluid oz. Bottle 12/Case

## Performance Low VOC Cleaner

Blasts away brake fluid, dirt and contaminants quickly and easily with no residue. Helps stop annoying brake squeal and chatter. Cleans disc and drum assemblies, including springs, rotors and pads. Great for your boat trailer!

**990A0-04E16-15Z** 14 oz. Can 12/Case



## Bond 1207B

1207B is used for sealing crankcases due to its outstanding resistance to heat and oil.

**990A0-06E70-03Z** 3.5 oz. Tube



## Thread Locks

Prevents nuts and bolts from vibrating loose. Made with the same compounds used to assemble Suzuki Products at the factory. Four strengths for different applications. Easy to use and store in individual 10cc containers with different colors for quick identification.

<b>990A0-06E33-10C</b>	1333B Medium Strength Bearing and Stud Lock
<b>990A0-06E03-10C</b>	1303 High Strength Retaining Type
<b>990A0-06E42-10C</b>	1342 Low Strength Frequent Repair
<b>990A0-06E60-10C</b>	1360 Medium Strength High Temperature Type



# MAINTENANCE AND CARE

## Marine Maintenance Kits

Suzuki Genuine Parts & Accessories is excited to introduce our new Marine Maintenance Kits. These all inclusive kits contain everything necessary for performing the recommended service.

Models	Part Number	Year
DF2.5	17400-97820	2006-2011
DF2.5	17400-97810	2012-Current
DF4/6	17400-91860	2002-2010
DF4/6	17400-91830	2011-2016
DF4A/6A	17400-91891	2017-Current
DF9.9A	17400-99841	2010-Current
DF9.9/15	17400-94810	2011-2013
DF9.9B/15A/20A	17400-89812	2013-Current
DF25/30	17400-89822	2001-2010
DF25 V-Twin	17400-95872	2006-2010
DF25A/30A	17400-94824	2015-Current
DF40/50	17400-87822	Late 2006-2010
DF60	17400-99852	Late 2009 Only
DF60/70	17400-99871	2007 Only
DF60/70	17400-99861	2008-Early 2009
DF40A/50A/60A	17400-88813	2010-Current
DF50AV/60AV	17400-88822	2014-Current
DF75A/80A/90A	17400-87813	2009-Current
DF115	17400-92842	2010-2012
DF140	17400-92852	2010-2012
DF115A/140A/115SS	17400-92823	2013-Current
DF115B/DF140B/G Models	99100-99100	2020-Current
DF150/175/150SS	17400-96824	2006-Current
DF150A/175A/200A	17400-96833	2016-Current
DF200/225/250 - V6	17400-93855	2011-Current
DF250AP/300AP/250SS	17400-98865	2011-Current
DF300B/350A	17400-98873	2017-Current
Kit Contents*	Oil Filter	
	Spark Plugs	
	Water Pump Kit	
	Fuel Filter	
	Water Pump Case Sleeve	
	Anodes	
	Cotter Pin	
	Gaskets	
O-Ring		

\*Kit Contents will vary slightly. See last two pages for specific kit contents

## Oil Filters

Oil filter part numbers by engine model. Engine oil capacities are for reference only. Please consult your engine owners manual for oil change procedure.

Models	Filter Part Number	Years	Oil Capacity w/out Filter L/QT	Oil Capacity w/Filter L/QT
DF4A/6A	16510-16H11	2017-Current	0.7/0.74	0.7/0.74
DF9.9T/9.9TH/9.9B/15/15A/20A	16510-45H10	2011-Current	1.0/1.1	1.1/1.2
DF9.9A	16510-05240	ALL	0.8/0.85	0.9/0.95
DF25/30	16510-87J01	ALL	1.5/1.6	1.6/1.7
DF25 V-Twin	16510-87J01	2006-2010	1.5/1.6	1.8/1.9
DF25A/30A	16510-87J01	2015-Current	1.5/1.6	1.6/1.7
DF40/50	16510-87J01	ALL	2.2/2.3	2.4/2.5
DF60/70	16510-87J01	ALL	4.5/4.8	4.8/5.1
DF40A/50A/60A	16510-87J01	2010-Current	2.7/3.0	2.9/3.2
DF75A/90A	16510-61A21-MHL	2009-2010	4.2/4.0	4.4/4.7
DF75A/90A	16510-61A32	2011-Current	4.2/4.0	4.4/4.7
DF90/115	16510-61A21-MHL	2001-2008	5.5/5.8	5.7/6.0
DF115A/115B/140A/140B/115SS	16510-61A32	2013-Current	5.5/5.8	5.7/6.0
DF140	16510-82703	2002-2012	5.5/5.8	5.7/6.0
DF150A/150SS/175A/200SS/200A	16510-96J11	2016-Current	8.0/8.5	8.5/9.0
DF200(V6)/225/250	16510-96J11	ALL	8.0/8.5	8.2/8.7
DF225T/250T/250SS/250AP/300AP	16510-96J11	2011-Current	8.0/8.5	8.2/8.7
DF300B/350A/300BMD/350AMD	16510-96J11	2017-Current	7.8/8.2	8.0/8.5

## Recommended Oil Change Periods

1st 20 hours Oil & Filter	Every 100 hours Oil	Every 200 hours Oil & Filters
------------------------------	------------------------	----------------------------------

## Oil Change Necessities/Oil Drain Plug Gasket

Engine Model	Drain Plug	Drain Plug Gasket
DF2.5	09248-10008	09168-10022
DF4/6	09248-10008	09168-10022
DF4A/6A	09248-12009	09168-12017
DF9.9A	09248-12009	09168-12017
DF9.9B/15A/20A	09248-12009	09168-12017
DF25/25 V-Twin/30	09248-12009	09168-12012
DF25A/30A	09248-12009	09168-12017
DF40/50	09248-12009	09168-12012
DF40A/50A/60A	09248-12009	09168-12012
DF60/70	09248-12009	09168-12012
DF75A/90A	09248-12009	09168-12012
DF90/115/115A/115B/140/140A/140B/G Models	09248-12009	09168-12012
DF150/150A/175/175A/200A	09248-12009	09168-12012
All V6 Models (Includes DF300B/350A)	09248-12009	09168-12012

## Bulk Oil Filters

All Bulk Packs contain 24 oil filters. They are not individually wrapped. Only meant for service departments, not resale.

Oil Filter Part Number	Bulk Pack Part Number
16510-61A32	16510-61832-B24
16510-82703	16510-82803-B24
16510-87J01	16510-87801-B24
16510-96J11	16510-96802-B24



## Flush Hose Attachment

See Owners Manual or Service Manual on how to use the flush attachments.

55181-95200	DF4 - DF15
17917-87L00	DF9.9A - 350A
99000-81210	DF300B/325A/350A/300BMD/350AMD (2023~)
99000-81220	DF250S (2023~)

## Spark Plugs



Models	Part Number	Year	Spark Plug	Models	Part Number	Year	Spark Plug
DF2.5	09482-00406	ALL	CR6HSA	DF40/50	09482-00446	ALL	DCPR6E
DF4/6	09482-00299	2003-2010	BPR6ES	DF60/70	09482-00299	ALL	BPR6ES
DF4/6	09482-00L04	2011-2016	CPR6EA-9	DF40A/50A/60A	09482-00446	2010-Current	DCPR6E
DF4A/6A	09482-00L04	2017-Current	CPR6EA-9	DF75A/90A	09482-00446	ALL	DCPR6E
DF9.9/15	09482-00446	1996-2003	DCPR6E	DF90, ALL DF115/140	09482-00427	ALL	BK6RE
DF9.9/15	09482-00427	2004-2011	BKR6E	DF115BSS/115B/140B	09482-00649	2022-Current	LK6RE
DF9.9A	09482-00528	ALL	CR6E	DF150/175	09482-00427	2006-2018	BK6RE
DF9.9B/15A/20A	09482-00L04	2013-2017	CPR6EA-9	DF150A/175A/200A	09482-00649	2019-Current	LK6RE
DF9.9B/15A/20A	09482-00661	2018-Current	MR6K-9	DF150AP/175AP/200AP	09482-00649	ALL	LK6RE
DF25 V-Twin	09482-00427	2006-2010	BKR6E	DF200(V6)/225/250	09482-00427	ALL	BK6RE
DF25/30	09482-00446	ALL	DCPR6E	DF250SS	09482-00427	ALL	BK6RE
DF25A/30A	09482-00L04	2015-2018	CPR6EA-9	DF300/300AP	09482-00427	ALL	BK6RE
DF25A/30A	09482-00661	2019-Current	MR6K-9	DF300B/350A	09482-00642	ALL	ILZKR7D8



## Suzuki Super Grease

Multi-purpose, lithium grease is heat and water resistant, anti-wear.

99000-25480



## Silicone Seal

A clear adhesive sealer with a silicone base.

93691-80030 3.5 oz. Tube



## Water Resistant Grease

Use on oil seal lips, links and joints of the engine that are below the waterline.

99000-25520 8.8 oz. Tube



## Touch-Up Paint

If you need touch-up paint for your outboard, please visit [www.colorrite.com](http://www.colorrite.com).

Black Outboards	Code
Shadow Black Metallic	0EP
Nebular Black	YAY
Metallic Matte Black	YKV

White Outboards	Code
Super Cool White	QTN
Cool White	Y5S
Pearl Anniversary White	QUA

Other	Code
2 Stroke Charcoal	0ED
Warm Silver - DF300B/350A Trim	20H



## Lower Unit Drain Plug Gaskets

Part Number	Models
59178-97J00	DF25A/30A
09168-10022	DF40-140B (excluding 70/90)
09168-10038	DF70A-90A, DF150-300A



# ENGINE COVERS

## Engine Covers

Custom-fit Engine Covers feature Sunbrella® UV resistant, water-repellent fabric and silk screened Suzuki graphics. Sunbrella is a registered trademark of Glen Raven, Inc.

New Part Number	For	Application
990C0-65012	DF2.5	All Model years
990C0-65013	DF4A/6A	All Model years
990C0-65022	DF9.9A/9.9B/15A/20A	2012 - Current
990C0-65023	DF25A/30A	All Model years
990C0-65024	DF40A/50A/60A	2011 - Current
990C0-65001	DF40/50	2010 and Prior
990C0-65026	DF75A/90A	2009 - Current
990C0-65027	DF115A/140A	2012 - Current
990C0-65004	DF140	2002 - 2011
990C0-65028	DF115BG/140BG	All Model years
990C0-65030	DF150/175	2006 - 2018
990C0-65031	DF150AP/175AP/200A	Will not fit DF150/175
990C0-65032	DF225/250/250T	Will not fit DF250AP
990C0-65033	DF250AP/300/300AP	All Model years
990C0-65034	DF300B/350A	All Model years



## Splash Covers

Suzuki vented Splash Covers are custom made, tight-fitting covers that are designed to protect the outboard engine cowlings and decals from sun, spray, salt, birds, errant fish hooks, and anything else that can compromise the factory finish while the engine is running. The Polysoft II fabric is a breathable, marine grade fabric that is 95% waterproof and 5% breathable which ensures that moisture will not be trapped under the cover. This 100% woven polyester fabric is UV stabilized to resist fading and rotting. The soft non-woven lining will not scuff or damage your cowling when installed. Splash Covers are easy to clean and will be sure to turn heads! Please note: all engine covers 150hp and up will have gray graphics, while all engine covers 140hp and below (including DF4/6 carry bag) will have red graphics.

Black Covers	White Covers	Application
990C0-67000-BLK	N/A	Carry Bag for DF4A/DF6A (2nd Generation)
990C0-67001-BLK	N/A	DF90/DF115 (1st Generation)
990C0-67003-BLK	N/A	DF140 (1st Generation)
990C0-67002-BLK	990C0-67002-WHT	DF115A/DF140A (2nd Generation)
990C0-67012-BLK	990C0-67012-WHT	DF115B/DF140B (3rd Generation, Including BG Models)
990C0-66000-BLK	N/A	DF150SS/DF150/DF175 (1st Generation)
990C0-66002-BLK	990C0-66002-WHT	DF150A/DF175A/DF200A (2nd Generation, Including AP Models)
990C0-66001-BLK	N/A	DF225/DF250 V6 Mechanical
990C0-66003-BLK	990C0-66003-WHT	DF250AP/DF300AP
990C0-66005-BLK	990C0-66005-WHT	DF300B
990C0-66004-BLK	990C0-66004-WHT	DF350A



# MARINE STYLE



## Suzuki Logo Tee

100% Ringspun Cotton. Screen-printed logo on front.

990A0-16242-__	Blue
	SML, MED, LRG, 1XL, 2XL

990A0-16243-__	Black
	SML, MED, LRG, 1XL, 2XL



## Sun

Navy premium soft cotton T-Shirt with graphics screen printed on the front.

990A0-16246-__	Navy
	MED, LRG, 1XL, 2XL



## Suzuki Wedge

Royal/Heather, Men's 3/4 raglan, 50% poly, 25% cotton, 25% rayon, 4.3 oz, Screen printed front and back

990A0-16290-__	Royal/Heather
	MED, LRG, 1XL, 2XL



## 'S' Bar

The Suzuki S-Bar T-Shirt features a charcoal T-Shirt, with the Suzuki "S" screen printed on the chest. Suzuki logotype is printed on the bottom.

990A0-16247-__	Gray
	MED, LRG, 1XL, 2XL



## Suzuki Nested Logo Tee

60% cotton-40% polyester knit blend.

990A0-16265-__	Black
	SML, MED, LRG, 1XL, 2XL



## Suzuki Center Red "S" Tee

60% cotton-40% polyester knit blend.

990A0-16266-__	Gray
	SML, MED, LRG, 1XL, 2XL



## Suzuki Team

Royal Men's crew T-shirt, 100% cotton 6 oz. jersey screen printed front, side and sleeve

990A0-16280-__	Royal
	MED, LRG, 1XL, 2XL



## Suzuki Big S

Black Men's crew T-shirt, 100% cotton 6 oz. Jersey, Screen printed front, side and sleeve

990A0-16281-__	Black
	MED, LRG, 1XL, 2XL



## Women's Suzuki Stripes Tee

Women's crew t-shirt 60% Cotton 40% poly 4.3 oz combed ring-spun screen printed front and sleeve.

990A0-16256-__	Royal Blue
	SML, MED, LRG, 1XL



## Ladies '86

100% Cotton. Tagless neck label. Screen-print on front.

990A0-16224-__	Gray
	SML, MED, LRG, 1XL

# MARINE STYLE



## Suzuki Circle Tee

Premium soft cotton T-Shirt with graphics screen printed on the front.

990A0-16300-___	Black
	SML, MED, LRG, 1XL, 2XL,3XL



## Suzuki Moving S Tee

Premium soft cotton T-Shirt with graphics screen printed on the front.

990A0-16301-___	Gray
	SML, MED, LRG, 1XL, 2XL,3XL



## Suzuki Crossword Tee

Premium soft cotton T-Shirt with graphics screen printed on the front.

990A0-16297-___	Soft Blue
	SML, MED, LRG, 1XL, 2XL,3XL



## Mechanics Shirts

65% Polyester, 35% Cotton. Features the SUZUKI logo embroidered on the left chest and Suzuki 'S' on right sleeve.

990A0-18112-___	Navy
	SML, MED, LRG, 1XL, 2XL, 3XL, 4XL
990A0-18113-___	Charcoal
	SML, MED, LRG, 1XL, 2XL, 4XL

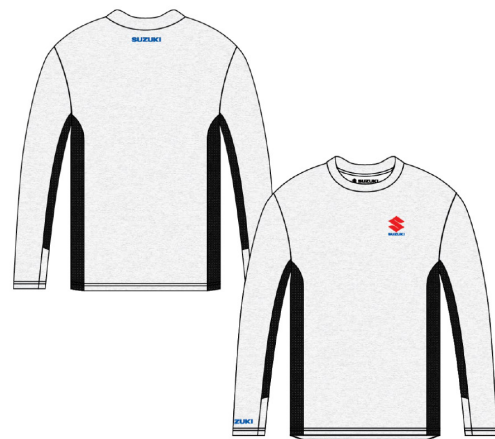

## Suzuki White Performance

4.75 oz., Moisture-Wicking, Antimicrobial, UPF 50+

990A0-16302-___	White
	SML, MED, LRG, 1XL, 2XL,3XL



## Suzuki 1/4 Zip Performance

4.75 oz., Moisture-Wicking, Antimicrobial, UPF 50+

990A0-15120-___	Gray
	SML, MED, LRG, 1XL, 2XL,3XL



## Suzuki Camo Performance

4.75 oz., Moisture-Wicking, Antimicrobial, UPF 50+

990A0-16303-___	Camo
	SML, MED, LRG, 1XL, 2XL,3XL



## Suzuki Ecstar Polo

3.8 oz polyester tricot, snag resistant, moisture wicking, tag free label. Features and embroidered Suzuki logo on left chest and ECSTAR® logo on the left sleeve.

990A0-18127-___	Men's Black	SML, MED, LRG, 1XL, 2XL, 3XL
990A0-18128-___	Men's Blue	SML, MED, LRG, 1XL, 2XL, 3XL
990A0-18129-___	Men's Gray	SML, MED, LRG, 1XL, 2XL, 3XL
990A0-18130-___	Women's Black	SML, MED, LRG, 1XL
990A0-18131-___	Women's Blue	SML, MED, LRG, 1XL
990A0-18132-___	Women's Gray	SML, MED, LRG, 1XL

# MARINE STYLE

## Charcoal Hat



990A0-17168 Charcoal



## Red S Performance Hat

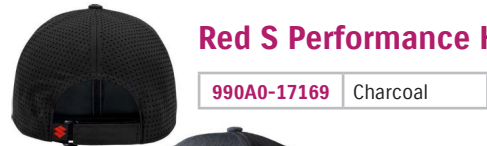

990A0-17169 Charcoal



## Gray S Performance Hat



990A0-17169 Charcoal



## Suzuki Marine Stretch-Fit Visor

The Stretch-Fit Visor is draped in Suzuki colors and features embroidered logos. This one-size fit most visor has an elastic band. Order in quantities of 3.

990C0-17005 White/Black  
S/M Stretch



## Vintage Trucker

The Suzuki Vintage Snap-back Hat features a black snap-back hat with the vintage Suzuki logo screen printed on the front panel. Order in quantities of 3.

990A0-17150 One Size Fits Most



## Suzuki Sideways Hat

3-D Embroidered Suzuki Logo. Order in quantities of 3.

990A0-17138 Suzuki Sideways Hat  
One Size Fits Most



## 3D Red "S" Gradation Cap

Flex-Fit X-Cap with 3D Red "S" Logo. Order in quantities of 3.

990A0-17107 Black/Red Logo  
One Size Fits Most



## Hat Black

100% cotton twill with polymesh back

990A0-17160 Black



## Olive Trucker Hat

990A0-17166 Olive



## Beanie Black

100% acrylic knit.

990A0-17181 Black



## Beanie Gray

100% acrylic knit.

990A0-17180 Gray



## Beanie Charcoal

990A0-17177 Charcoal

## Suzuki Mark Trucker Hat

This trucker-style hat is gray with a black bill and features a black Suzuki "S" patch sewn onto the front panel.

990A0-17151 Black/Red Logo  
One Size Fits Most



## 3D Blue "S" Gradation Cap

Flex-Fit X-Cap with 3D Blue "S" Logo. Order in quantities of 3.

990A0-17108 Black/Blue Logo  
One Size Fits Most



## Suzuki Soft Shell Jacket

Navy Soft-Shell Jacket, 100% polyester water resistant, micro fleece lining, scuba hood, media pocket, chest print and sleeve patch

990A0-15101-\_\_\_ Navy  
MED, LRG, 1XL, 2XL



## Suzuki Performance Full-zip Hoodie

7.1 oz, 100% Polyester, Smooth face with comfy fleece backing, Snag-resistant and pill-resistant, Double-knit construction enhances breathability while providing excellent warmth and comfort, Moisture wicking 3-piece lined hood, Comfort Stretch Cuffs & Waistband, Black YKK Zipper

990A0-15101-\_\_\_ Charcoal  
SML, MED, LRG, 1XL, 2XL



## Sublimated Polo Dark Gray

100% performance knit polyester.

990A0-18134-\_\_\_ Gray  
SML, MED, LRG, 1XL, 2XL, 3XL



## Logo Polo Black

100% performance knit polyester.

990A0-18135-\_\_\_ Black  
SML, MED, LRG, 1XL, 2XL, 3XL



## Suzuki UPF Sun Shirt Gray

100% performance knit polyester.

990A0-16267-\_\_\_ Gray  
SML, MED, LRG, 1XL, 2XL



## Suzuki Logo Hoodie

Black hooded pullover sweatshirt, 80% cotton 20% poly, 7 Oz. mid-weight fleece, screen printed graphics.

990A0-15104-\_\_\_ Black  
MED, LRG, 1XL, 2XL



## Suzuki Retro Contrast Hoodie

Midweight varsity contrast hooded sweatshirt 8.3 oz. 80% Ringspun cotton 20% Polyester.

990A0-15117-\_\_\_ Gray  
SML, MED, LRG, 1XL, 2XL,3XL



## Suzuki Contrast Hoodie

Midweight varsity contrast hooded sweatshirt 8.3 oz. 80% Ringspun cotton 20% Polyester.

990A0-15119-\_\_\_ Black  
SML, MED, LRG, 1XL, 2XL,3XL



## Suzuki Fleece 1/4 Zip Jacket

9.4oz 100% Polyester, Anti-pill fabric, Storm placket with chinguard, Center front coil zipper with rubber pull, Stretch binding at neck, Raglan sleeves

990A0-15109-\_\_\_ Ash  
SML, MED, LRG, 1XL, 2XL,3XL



## Softshell Jacket

100% polyester bonded waterproof shell.

990A0-15100-\_\_\_ Black  
MED, LRG, 1XL, 2XL

# GIFTS AND COLLECTIBLES



## Suzuki Backpacks

990A0-19094	Port Authority (right)
990A0-19093	OGIO (left)



## Suzuki Key Fobs

Made of flexible rubber, Key Fob features the Suzuki Corporate Logo. Dealers order in packs of 3.

990A0-19113	Suzuki 'S' Logo
990A0-19112	Suzuki Logo



## Suzuki Logo Water Bottle

Lightweight and durable, branded with the classic Suzuki logo.

990A0-99106

## Suzuki Merchandise Bags

Available in your choice of paper or plastic with Suzuki graphics in 500 piece packages.

99950-19371	Paper	12" H x 6" W
99950-19372	Plastic	13" H x 12" W



## Suzuki Logo Die-Cut Decals

Thermal die-cut vinyl Official Suzuki Logo available in sizes from 4" to 20". Dealers order in packs of 5.

99950-19245-MED	Suzuki Logo	12"
99950-19245-LRG	Suzuki Logo	20"



## Suzuki Carabiner Flashlight

990A0-19310



## Suzuki Umbrella

Protect yourself from the weather with a Suzuki Umbrella.

990A0-99178



## Suzuki Coffee Mug

This 16 oz Mug features an extra large comfort-grip handle.

990A0-99184



## Suzuki Logo Can Koozie

Keep your favorite drink cold in this Suzuki Can Koozie! Sublimated Suzuki Logo resists fading or chipping.

990A0-19206



## Suzuki String Pennant

50 foot String Pennants are made with a durable 4mm vinyl.

990A0-99303-WHT 50' String Pennant



## Suzuki Shelter

Protect yourself and your gear from the elements while outside. These canopies feature durable canvas covers, aluminum frames, and silk screened Suzuki branding. When you're ready to pack it up for the day, simply fold it down and store them in their own canvas carrying case.

990A0-99279



## Vinyl Banners

Suzuki banners are a great way to increase the presence of Suzuki in and outside of your dealership. They are also great for events.

990A0-99301-WHT	4' x 20"
990A0-99302-WHT	3' x 10"



## Suzuki Logo Decals

Suzuki Decals are made with durable 15 mil, UV resistant coated vinyl decals. All Decals are sold in QTYS of 1.

990A0-99290-006	6"
990A0-99290-012	12"
990A0-99290-024	24"
990A0-99290-048	48"



## Suzuki Ecstar Tables

Perfect for any garage or shop, Suzuki branded tables feature chrome plated steel tubing and melamine coated tops.

990A0-96380 Suzuki Ecstar Logo Table



## Suzuki Stools

Dress up your garage or shop with these comfortable padded stools. Each stool is covered in an easy to clean vinyl material and features Suzuki branding and are constructed using chrome plated steel tubing.

990A0-95520 Suzuki Ecstar Logo Stool



## Garage & Shop Mats

Light and strong 100% olefin carpet pile with non-skid vinyl backing and 1-inch tapered border. 36 inch x 60 inch

990A0-95535	Suzuki Logo Mat
990A0-95539	Ecstar Logo Mat

# APPLICATION CHART

## DF4/6A (2017 - Current)

Side Mount Control Box	<b>67200-91J32</b>
Remote Control Attatching Kit	<b>67101-97L01</b>
Battery Charging Kit	<b>32000-97L10</b>
Spark Plug (CPR6EA-9)	<b>09482-00L04</b>
Water Pump Repair Kit	<b>17400-986L2</b>
Oil Filter	<b>16510-16H11</b>
Maintenance Kit	<b>17400-91891</b>
Flush Hose Attatchment	<b>55181-95200</b>

## DF9.9A (2010 - 2012)

Side Mount Control Box	<b>67200-91J32</b>	
Remote Control Attatching Kit	<b>67130-99J02</b>	
Water Pump Repair Kit	<b>17400-99J02</b>	
Electric Starter Set	<b>31000-99J00</b>	
Battery Charging Kit	<b>32000-99J00</b>	
Oil Filter	<b>16510-05240</b>	'10
	<b>16510-45H10</b>	'11 - Current
Drag Link	<b>67701-99J02</b>	
Propeller Hardware Kit	<b>57630-99J00</b>	
Spark Plug CR6E	<b>09482-00528</b>	

## DF25A/30A (2015 - Current)

Side Mount Control Box	<b>67200-94J33</b>	w/ Warning Buzzer w/o PTT Switch
Side Mount Control Box	<b>67200-93J62</b>	w/ PTT Switch, up to 2021
Side Mount Control Box	<b>67200-93J70</b>	w/ PTT Switch, 2022 - Current
Remote Control Attatching Kit	<b>67130-94L03</b>	
	<b>67130-94L13</b>	Tiller Handle Models
Remote Control Cables	<b>990C0-11002-0XX*</b>	
Single Binnacle	<b>67200-88L02</b>	
Flush Mount Remote Control	<b>67200-93J34</b>	
Wire Harness 21'	<b>36620-94L20</b>	
Modular Ignition Panel	<b>37803-98L00</b>	
Single Vertical Ign. Sw. Panel Assy.	<b>37100-98L10</b>	
Single Horizontal Ign. Sw. Panel Assy.	<b>37100-98L20</b>	
Warning Buzzer	<b>38500-93J90</b>	
Emergency Stop Assy.	<b>37803-98L00</b>	
Drag Link Kit	<b>67701-94L00</b>	
Propeller Hardware Kit	<b>57630-96300</b>	
Water Pump Repair Kit	<b>17400-94L21</b>	
Maintenance Kit	<b>17400-94824</b>	
Spark Plug CPR6EA-9	<b>09482-00L04</b>	2015-2018
Spark Plug MR6K-9	<b>09482-00661</b>	2019-Current
Oil Filter	<b>16510-87J01</b>	

## DF9.9/15 (1996 - 2009)

Side Mount Control Box	<b>67200-91J32</b>	'05 - Current
Remote Control Attatching Kit	<b>67130-94J12</b>	'05 - Current
Remote Control Cables	<b>990C0-11002-0XX*</b>	2 req'd
Harness, Remote Control	<b>36630-89E02***</b>	'96 - '04
Main Harness	<b>36620-89L00</b>	'05 - Current
Water Pump Repair Kit	<b>17400-93951</b>	'96 - '06
	<b>17400-94J00</b>	'07 - Current
Steering Bracket Attachment	<b>67720-93E00</b>	
Tilt-Tube Attachment	<b>41141-89E00</b>	
Rectifier Set	<b>32800-95D02</b>	'96 - '04
	<b>32800-94J11</b>	'05 - Current
Rectifier Regulator	<b>32801-94J01</b>	'05 - Current
Battery Charging Kit	<b>32000-94J02</b>	'05 - Current
Choke Solenoid	<b>38610-93E00</b>	'96 - '04
Bolts	<b>01550-06167</b>	2 req'd
	<b>31101-95D20-0EP</b>	'96 - '03
Starter Motor Set Stator, 120W	<b>31100-94J22</b>	'05 - Current
	<b>32120-94J10</b>	'06 - Current
Flywheel, Ring Gear Type	<b>32102-94J10</b>	'05 - Current
Propeller Hardware Kit	<b>57630-93900</b>	
Drag Link Assembly	<b>67701-93E12</b>	'97 - Current
Spark Plug	DCPR6E <b>09482-00446</b>	up to '04
	BKR6E <b>09482-00427</b>	'04 - Current
	CPR6-EA-9 <b>09482-00L04</b>	'11 - Current
Oil Filter	DF9.9/15 <b>16510-05240</b>	'96 - Current
	DF9.9T/15 <b>16510-45H10</b>	'11 - Current

## DF9.9B/15A/20A (2013 - Current)

Side Mount Control Box	<b>67200-94J33</b>	w/ Warning Buzzer, no PTT
Side Mount Control Box	<b>67200-93J62</b>	w/ PTT Switch, up to 2021
Side Mount Control Box	<b>67200-93J70</b>	w/ PTT Switch, 2022 - Current
Remote Control Mounting Kit	<b>67130-89L22</b>	
Remote Control Cables	<b>990C0-11002-0XX*</b>	
Single Binnacle	<b>67200-88L02</b>	
Flush Mount Remote Control	<b>67200-93J34</b>	
Wire Harness 21'	<b>36620-89L10</b>	
Modular Ignition Panel	<b>37803-98L00</b>	
Single Vertical Ign. Sw. Panel Assy.	<b>37100-98L10</b>	
Single Horiz. Ign. Sw. Panel Assy.	<b>37100-98L20</b>	
Warning Buzzer	<b>38500-93J90</b>	
Emergency Stop Assy.	<b>37803-98L00</b>	
Drag Link Kit	<b>67701-99J02</b>	
Propeller Hardware Kit	<b>57630-93901</b>	
Water Pump Repair Kit	<b>17400-99J20</b>	
Maintenance Kit	<b>17400-89812</b>	
Spark Plug CPR6EA-9	<b>09482-00L04</b>	2013-2017
Spark Plug MR6K-9	<b>09482-00661</b>	2018-Current
Oil Filter	<b>16510-45H10</b>	

## DF/75A/90A (2009 - Current)

Side Mount Control Box	<b>67200-93J62</b>	w/ PTT Switch, up to 2021
Side Mount Control Box	<b>67200-93J70</b>	w/ PTT Switch, 2022 - Current
Remote Control Cables	<b>990C0-11002-0XX*</b>	2 Req'd
Single Binnacle	<b>67200-88L02</b>	
Dual Binnacle	<b>67200-88L12</b>	
Flush Mount Remote Control	<b>67200-93J34</b>	
Wire Harness 16'	<b>36620-93J80</b>	
Wire Harness 21'	<b>36620-93J70</b>	
Wire Harness 26'	<b>36620-93J90</b>	
Power Trim/Tilt Switch	<b>37805-88L00</b>	
Modular Ignition Panel	<b>37100-98L00</b>	
Dual Ign. Sw. Panel Assy.	<b>37100-98L30</b>	
Single Vertical Ign. Sw. Panel Assy.	<b>37100-98L10</b>	
Single Horizontal Ign. Sw. Panel Assy.	<b>37100-98L20</b>	
Troll Mode Switch Panel	<b>37860-98L00</b>	
Warning Buzzer	<b>38500-93J90</b>	
Emergency Stop Assy.	<b>37803-98L00</b>	
Dual Engine Tie Bar	<b>990C0-10006</b>	2009-2021
Drag Link Kit	<b>67700-87L01</b>	
	<b>67700-87L10</b>	2022-Current
Tiller Handle Kit w/ Tach.	<b>63002-87L20-YAY</b>	2022-Current
Propeller Hardware Kit	<b>57630-90J10</b>	
Maintenance Kit	<b>17400-87813</b>	
Water Pump Repair Kit	<b>17400-87L04</b>	
Spark Plug DCPR6E	<b>09482-00446</b>	
Oil Filter	<b>16510-61A32</b>	

## DF115A/140A/115SS (2013-2022)

Flush Mount Control Box	<b>67200-93J34</b>	
Remote Control Cables	<b>990C0-11002-0XX*</b>	2 Req'd
Single Binnacle	<b>67200-88L02</b>	
Dual Binnacle	<b>67200-88L12</b>	
Flush Mount Remote Control	<b>67200-93J34</b>	
Wire Harness 16'	<b>36620-93J80</b>	
Wire Harness 21'	<b>36620-93J70</b>	
Wire Harness 26'	<b>36620-93J90</b>	
Power Trim/Tilt Switch	<b>37805-88L00</b>	
Modular Ignition Panel	<b>37100-98L00</b>	
Dual Ign. Sw. Panel Assy.	<b>37100-98L30</b>	
Single Vertical Ign. Sw. Panel Assy.	<b>37100-98L10</b>	
Single Horizontal Ign. Sw. Panel Assy.	<b>37100-98L20</b>	
Troll Mode Switch Panel	<b>37860-98L00</b>	
Warning Buzzer	<b>38500-93J90</b>	
Emergency Stop Assy.	<b>37803-98L00</b>	
Dual Engine Tie Bar	<b>990C0-10006</b>	
Drag Link Kit	<b>67701-90J01</b>	
Tiller Handle Kit w/ Tach.	<b>63002-90J38-YAY</b>	DF115A
Propeller Hardware Kit	<b>57630-90J10</b>	
Maintenance Kit	<b>17400-92823</b>	
Water Pump Repair Kit	<b>17400-92J23</b>	
Spark Plug BKR6E	<b>09482-00427</b>	
Oil Filter	<b>16510-61A32</b>	

## DF40A/50A/50AV/60A/60AV (2010 - Current)

Side Mount Control Box	<b>67200-93J62</b>	w/ PTT Switch, up to 2021
Side Mount Control Box	<b>67200-93J70</b>	w/ PTT Switch, 2022 - Current
Remote Control Cables	<b>990C0-11002-0XX*</b>	2 Req'd
Single Binnacle	<b>67200-88L02</b>	
Dual Binnacle	<b>67200-88L12</b>	
Flush Mount Remote Control	<b>67200-93J34</b>	
Wire Harness 16'	<b>36620-93J80</b>	
Wire Harness 21'	<b>36620-93J70</b>	
Wire Harness 26'	<b>36620-93J90</b>	
Power Trim/Tilt Switch	<b>37805-88L00</b>	
Modular Ignition Panel	<b>37100-98L00</b>	
Dual Ign. Sw. Panel Assy.	<b>37100-98L30</b>	
Single Vertical Ign. Sw. Panel Assy.	<b>37100-98L10</b>	
Single Horizontal Ign. Sw. Panel Assy.	<b>37100-98L20</b>	
Troll Mode Switch Panel	<b>37860-98L00</b>	
Warning Buzzer	<b>38500-93J90</b>	
Emergency Stop Assy.	<b>37803-98L00</b>	
Dual Engine Tie Bar	<b>990C0-10006</b>	
Steering Tensioner	<b>43770-99E03</b>	
Drag Link Kit	<b>67701-87J11</b>	DF40A/50A/60A
Propeller Hardware Kit	<b>57630-94301</b>	DF50AV/60AV
	<b>57630-90J00</b>	
Tiller Handle Kit w/ Tach.	<b>63002-88L2A-YAY</b>	DF40A/50A/60A
	<b>63002-88L18-YAY</b>	DF50AV/60A/60AV
Maintenance Kit	<b>17400-88812</b>	DF50AV/60AV
	<b>17400-88822</b>	DF40A/50A/60A
Water Pump Repair Kit	<b>17400-88L01</b>	DF50AV/60AV
	<b>17400-99E12</b>	
Spark Plug DCP6RE	<b>09482-00446</b>	
Oil Filter	<b>16510-87J01</b>	

## DF115B/140B (G Models Included)

Side Mount Control Box	<b>67200-93J34</b>	
Remote Control Cables	<b>990C0-11002-0XX*</b>	2 Req'd
Single Binnacle	<b>67200-88L02</b>	
Dual Binnacle	<b>67200-88L12</b>	
Flush Mount Remote Control	<b>67200-93J34</b>	
Wire Harness 16'	<b>36620-93J80</b>	
Wire Harness 21'	<b>36620-93J70</b>	
Wire Harness 26'	<b>36620-93J90</b>	
Power Trim/Tilt Switch	<b>37805-88L00</b>	
Modular Ignition Panel	<b>37100-98L00</b>	
Dual Ign. Sw. Panel Assy.	<b>37100-98L30</b>	
Single Vertical Ign. Sw. Panel Assy.	<b>37100-98L10</b>	
Single Horizontal Ign. Sw. Panel Assy.	<b>37100-98L20</b>	
Troll Mode Switch Panel	<b>37860-98L00</b>	
Warning Buzzer	<b>38500-93J90</b>	
Emergency Stop Assy.	<b>37803-98L00</b>	
Drag Link Kit	<b>67701-90J01</b>	
Propeller Hardware Kit	<b>57630-90J10</b>	
Water Pump Repair Kit	<b>17400-92J23</b>	
Spark Plug LKR6E	<b>09482-00649</b>	
Oil Filter	<b>16510-61A32</b>	

### Specific Application Notes:

\* Cable is available in one foot increments from 8 to 25 feet. (example: 008 = 8 ft, 025 = 25 ft)

\*\* Must use with one of the following Main Harnesses: 16": 36620-93J80 21": 36620-93J70 25": 36620-93J90

\*\*\* Under-Hood Electric Start Harness

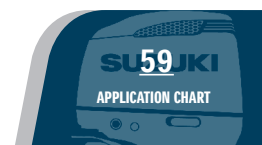
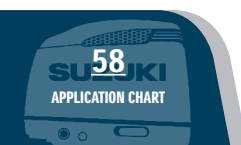

# APPLICATION CHART

## DF150A/150SS/175A/200A/200SS

Flush Mount Control Box	67200-93J34	
Remote Control Cables	990C0-11002-OXX*	2 Req'd
Single Binnacle	67200-88L02	
Dual Binnacle	67200-88L12	
Flush Mount Binnacle	67200-93J34	
Wire Harness 16'	36620-93J80	
Wire Harness 21'	36620-93J70	
Wire Harness 26'	36620-93J90	
Power Trim/Tilt Switch	37805-88L00	
Modular Ignition Panel	37100-98L00	
Dual Ign. Sw. Panel Assy.	37100-98L30	
Single Vertical Ign. Sw. Panel Assy.	37100-98L10	
Single Horizontal Ign. Sw. Panel Assy.	37100-98L20	
Troll Mode Switch Panel	37860-98L00	
Warning Buzzer	38500-93J90	
Emergency Stop Assy.	37803-98L00	
Dual Engine Tie Bar	67600-93J00	
Drag Link Kit	67701-96J00	
Propeller Hardware Kit (Watergrip)	57630-93L00	
Propeller Hardware Kit (Non-Watergrip)	57630-92E00	
Maintenance Kit	17400-96833	
Water Pump Repair Kit	17400-96J04	DF150A/175A/200A
Spark Plug BK6RE	09482-00427	
Spark Plug LK6RE	09482-00649	2019 and Newer
Oil Filter	16510-96J11	

## DF225/250 (2004 - Current)

Flush Mount Control Box	67200-93J34	
Remote Control Cables	990C0-11002-OXX*	2 Req'd
Single Binnacle	67200-88L02	
Dual Binnacle	67200-88L12	
Flush Mount Binnacle	67200-93J34	
Wire Harness 16'	36620-93J80	
Wire Harness 21'	36620-93J70	
Wire Harness 26'	36620-93J90	
Power Trim/Tilt Switch	37805-88L00	
Modular Ignition Panel	37100-98L00	
Dual Ign. Sw. Panel Assy.	37100-98L30	
Single Vertical Ign. Sw. Panel Assy.	37100-98L10	
Single Horizontal Ign. Sw. Panel Assy.	37100-98L20	
Troll Mode Switch Panel	37860-98L00	
Warning Buzzer	38500-93J90	
Emergency Stop Assy.	37803-98L00	
Drag Link Kit	67700-93J00	
Propeller Hardware Kit (Watergrip)	57630-93L00	
Propeller Hardware Kit (Non-Watergrip)	57630-92E00	
Maintenance Kit	17400-93855	
Water Pump Repair Kit	17400-98J05	
Spark Plug BK6RE	09482-00427	
Oil Filter	16510-96J11	

## DF250SS Mechanical (2008 - Current)

Flush Mount Control Box	67200-93J34	
Remote Control Cables	990C0-11002-OXX*	2 Req'd
Single Binnacle	67200-88L02	
Dual Binnacle	67200-88L12	
Flush Mount Binnacle	67200-93J34	
Wire Harness 16'	36620-93J80	
Wire Harness 21'	36620-93J70	
Wire Harness 26'	36620-93J90	
Power Trim/Tilt Switch	37805-88L00	
Modular Ignition Panel	37100-98L00	
Dual Ign. Sw. Panel Assy.	37100-98L30	

Single Vertical Ign. Sw. Panel Assy.	37100-98L10	
Single Horizontal Ign. Sw. Panel Assy.	37100-98L20	
Troll Mode Switch Panel	37860-98L00	
Warning Buzzer	38500-93J90	
Emergency Stop Assy.	37803-98L00	
Drag Link Kit	67700-93J00	
Propeller Hardware Kit (Watergrip)	57630-93L00	
Propeller Hardware Kit (Non-Watergrip)	57630-92E00	
Maintenance Kit	17400-98865	
Water Pump Repair Kit	17400-98J05	
Spark Plug BK6RE	09482-00427	
Oil Filter	16510-96J11	

## DF115BG/140BG/150AP/175AP/200AP

Single Engine Binnacle First Station Kit	67000-98L03	
Single Engine Binnacle Second Station Kit	67000-98LA4	
Dual Engine First Station Kit	67000-98L24	
Dual Engine Second Station Kit	67000-98LC4	
Triple Engine First Station Kit	67000-98L33	
Triple Engine Second Station Kit	67000-98LD4	
Quad Engine First Station Kit	67000-98L42	
Quad Engine Second Station Kit	67000-98LE4	
Flush Mount First Station Kit	67000-98L13	
Flush Mount Second Station Kit	67000-98LB4	
Remote Control Assembly, Single	67200-98L00	
Remote Control Assembly, Dual	67200-98L10	
Remote Control Assembly, Flush	67200-98L20	
Counter Select Connector	36612-98J20	
Dual Engine Control Panel	37120-98L00	
Triple Engine Control Panel	37120-98L10	

Quad Engine Control Panel, PORT	37120-98L20	
Quad Engine Control Panel, STBD	37120-98L30	
Vertical Switch Panel	37100-98L10	
Horizontal Switch Panel	37100-98L20	
Modular Ignition Panel	37100-98L00	
Emergency Stop Switch	37803-98L00	
Troll Mode Switch Panel	37860-98L00	
Warning Buzzer	38500-93J90	
Dual Engine Tie Bar	67600-99L00	115BG/140BG
Dual Engine Tie Bar	67600-93J00	150AP/175AP/200AP
Drag Link Kit	67701-96J00	150AP/175AP/200AP
Propeller Hardware Kit	57630-90J10	115BG/140BG
Propeller Hardware Kit	57630-93L00	150AP/175AP/200AP
Maintenance Kit	17400-96833	150AP/175AP/200AP
Spark Plug LK6RE	09482-00649	
Oil Filter	16510-61A32	115BG/140BG
Oil Filter	16510-96J11	150AP/175AP/200AP

## DF250AP/300AP

Single Engine Binnacle First Station Kit	67000-98L03	
Single Engine Binnacle Second Station Kit	67000-98LA4	
Dual Engine First Station Kit	67000-98L24	
Dual Engine Second Station Kit	67000-98LC4	
Triple Engine First Station Kit	67000-98L33	
Triple Engine Second Station Kit	67000-98LD4	
Quad Engine First Station Kit	67000-98L42	
Quad Engine Second Station Kit	67000-98LE4	
Flush Mount First Station Kit	67000-98L13	
Flush Mount Second Station Kit	67000-98LB4	
Remote Control Assembly, Single	67200-98L00	
Remote Control Assembly, Dual	67200-98L10	
Remote Control Assembly, Flush	67200-98L20	
Counter Select Connector	36612-98J20	
Dual Engine Control Panel	37120-98L00	
Triple Engine Control Panel	37120-98L10	

Quad. Engine Control Panel, PORT	37120-98L20	
Quad. Engine Control Panel, STBD.	37120-98L30	
Vertical Switch Panel	37100-98L10	
Horizontal Switch Panel	37100-98L20	
Modular Ignition Panel	37100-98L00	
Emergency Stop Switch	37803-98L00	
Troll Mode Switch Panel	37860-98L00	
Warning Buzzer	38500-93J90	
Drag Link Kit	67700-93J00	
Propeller Hardware Kit (Watergrip)	57630-93L00	
Propeller Hardware Kit (Non-Watergrip)	57630-92E00	
Maintenance Kit	17400-98865	
Water Pump Repair Kit	17400-98J05	
Spark Plug BK6RE	09482-00427	
Oil Filter	16510-96J11	

## DF300B/300BMD/350A/350AMD

Single Engine Binnacle First Station Kit	67000-98L03	
Single Engine Binnacle Second Station Kit	67000-98LA4	
Dual Engine First Station Kit	67000-98L24	
Dual Engine Second Station Kit	67000-98LC4	
Triple Engine First Station Kit	67000-98L33	
Triple Engine Second Station Kit	67000-98LD4	
Quad Engine First Station Kit	67000-98L42	
Quad Engine Second Station Kit	67000-98LE4	
Flush Mount First Station Kit	67000-98L13	
Flush Mount Second Station Kit	67000-98LB4	
Remote Control Assembly, Single	67200-98L00	
Remote Control Assembly, Dual	67200-98L10	
Remote Control Assembly, Flush	67200-98L20	
Counter Select Connector	36612-98J20	
Dual Engine Control Panel	37120-98L00	

Triple Engine Control Panel	37120-98L10	
Quad. Engine Control Panel, PORT	37120-98L20	
Quad. Engine Control Panel, STBD.	37120-98L30	
Vertical Switch Panel	37100-98L10	
Horizontal Switch Panel	37100-98L20	
Modular Ignition Panel	37100-98L00	
Emergency Stop Switch	37803-98L00	
Troll Mode Switch Panel	37860-98L00	
Warning Buzzer	38500-93J90	
Propeller Hardware Kitn (Front)	58540-98L10	
Propeller Hardware Kitn (Rear)	58640-98L10	
Maintenance Kit (2017 - 2022)	17400-98873	
Water Pump Repair Kit (2017 - 2022)	17400-98L03	
Water Pump Repair Kit (~23 - Newer)	17400-87M00	
Spark Plug ILZKR7D8	09482-00642	
Oil Filter	16510-96J11	

### Specific Application Notes:

\* Cable is available in one foot increments from 8 to 25 feet. (example: 008 = 8 ft, 025 = 25 ft)

\*\* Must use with one of the following Main Harnesses: 16": 36620-93J80 21": 36620-93J70 25": 36620-93J90

\*\*\* Under-Hood Electric Start Harness

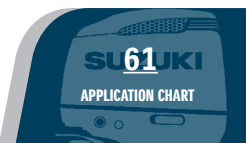
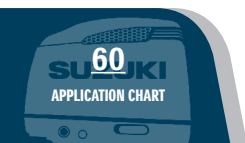







**MECHANICAL AND DIGITAL CONTROLS**

**CABLES AND RIGGING**

**FUEL SYSTEM**

**PROPS**

**INSTRUMENTS AND GAUGES**

**REPAIR AND MAINTENANCE KITS**

**ECSTAR® OIL AND CHEMICALS**

**ENGINE COVERS**

**SUZUKI STYLE APPAREL**

All information, illustrations, photographs and specifications contained in this catalog are based on the latest product information available at the time of publication. Due to improvements or other changes, there may be some discrepancies in this brochure. Suzuki reserves the right to make production changes at any time, without notice and without incurring any obligation to make the same or similar changes to accessories previously built or sold.

Note: Some items may require installation by an Authorized Suzuki Marine Dealer.



**SUZUKI MARINE USA, LLC**

13521 Prestige Place, Tampa, FL 33635  
[www.suzukimarine.com](http://www.suzukimarine.com) | [www.suzuki.com](http://www.suzuki.com)

©Suzuki Marine USA, LLC 2024 Printed in USA, Jan. 2024 / Part Number 990C0-12024